

# ROBE

## Cuete<sup>®</sup>

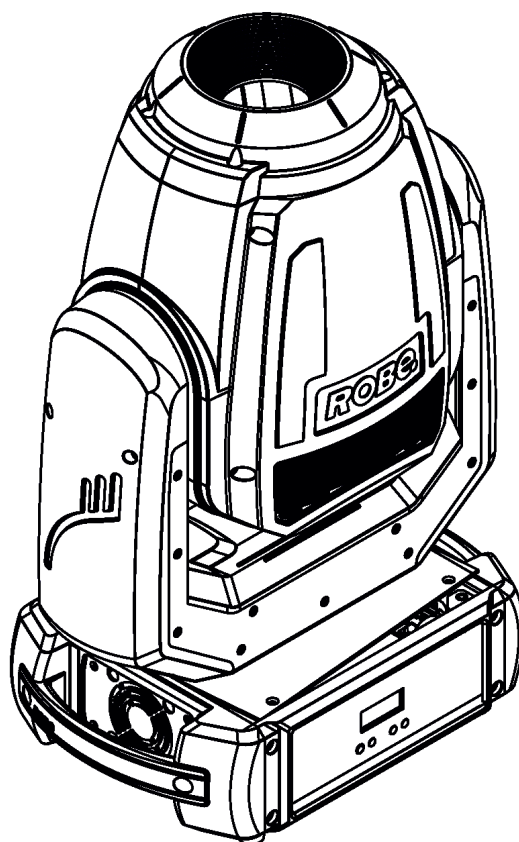

**ROBE**  
Innovative  
Technology

QR code for user manual



## USER MANUAL

ROBE<sup>®</sup> lighting s.r.o. • Czech Republic • [www.robe.cz](http://www.robe.cz)

Version 1.8

# Cuete

## Table of contents

<b>1. Safety instructions</b> .....	<b>3</b>
<b>2. Fixture exterior view</b> .....	<b>5</b>
<b>3. Installation</b> .....	<b>6</b>
3.1 Connection to the mains .....	6
3.2 Rigging the fixture .....	7
3.3 DMX-512 connection.....	9
3.4 Ethernet connection (EP version only).....	10
3.5. Wireless DMX operation .....	11
3.6. Wide-angle lens installation .....	12
3.7. Replacing rotating gobos .....	13
<b>4. Remotely controllable functions</b> .....	<b>14</b>
<b>5. Control menu map</b> .....	<b>15</b>
<b>6. Control menu</b> .....	<b>18</b>
6.1 Addressing (DMXA).....	18
6.2 Fixture information (Info).....	18
6.3 Personality (Pers).....	19
6.4 Manual Control (Manual).....	20
6.5 Test program (Test Prg).....	20
6.6 Stand-alone (St Alone).....	21
6.7 Reset.....	22
6.8 Special functions (Special).....	22
<b>7. RDM</b> .....	<b>24</b>
<b>8. Error and information messages</b> .....	<b>25</b>
<b>9. Robe Ethernet Access Portal (REAP)</b> .....	<b>26</b>
<b>10. Technical Specifications</b> .....	<b>27</b>
<b>11. Maintenance and cleaning</b> .....	<b>30</b>
11.1 Replacing the fuse.....	30
11.2 Checking plastic parts of the fixture.....	31
11.3 Disposing of the product.....	31
<b>12. Photometric diagrams</b> .....	<b>32</b>
<b>13. ChangeLog</b> .....	<b>33</b>
<b>14. Appendix</b> .....	<b>34</b>
14.1 Changing the LED light source .....	34
14.2. Obtaining information about the LED light source by mobile phone .....	36

**FOR YOUR OWN SAFETY, PLEASE READ THIS USER MANUAL CAREFULLY  
BEFORE POWERING OR INSTALLING YOUR ROBIN Cuete !**

**Save it for future reference.**

This device has left our premises in absolutely perfect condition. In order to maintain this condition and to ensure a safe operation, it is absolutely necessary for the user to follow the safety instructions and warning notes written in this manual.

The manufacturer will not accept liability for any resulting damages caused by the non-observance of this manual or any unauthorized modification to the device.

Please consider that damages caused by manual modifications to the device are not subject to warranty.

**The Robin Cuete was designed for indoor use and it is intended for professional application only. It is not for household use.**

## 1. Safety instructions

**DANGEROUS VOLTAGE CONSTITUTING A RISK OF ELECTRIC SHOCK IS PRESENT WITHIN THIS UNIT!**

Make sure that the available voltage is not higher than stated on the rear panel of the fixture. This fixture should be operated only from the type of power source indicated on the marking label. If you are not sure of the type of power supplied, consult your authorized distributor or local power company.

WARNING! This unit does not contain an ON/OFF switch. Always disconnect power input cable to completely remove power from unit when not in use or before cleaning or servicing the unit.

Make sure that the power cord is never crimped or damaged by sharp edges. Check the fixture and the power cord from time to time.

Refer servicing to qualified service personnel.

**This fixture falls under protection class I. Therefore this fixture has to be connected to a mains socket outlet with a protective earthing connection.**

Do not connect this fixture to a dimmer pack.

**LED light emission. Risk of eye injury. Do not look into the beam at short distance of the of the product. Do not view the light output with optical instruments or any device that may concentrate the beam.**

If the fixture has been exposed to drastic temperature fluctuation (e.g. after transportation), do not switch it on immediately. The arising condensation water might damage your device. Leave the device switched off until it has reached room temperature.

Avoid brute force when installing or operating the fixture.

This fixture was designed for indoor use only, do not expose this unit to rain or use near water.

When choosing the installation spot, please make sure that the fixture is not exposed to extreme heat, moisture or dust.

Air vents and slots in the fixture's head and base are provided for ventilation, to ensure reliable operation of the device and to protect it from overheating.

**Do not block the front lens with any object when the fixture is under operation.**

**CAUTION! Risk group 2, RG-2**



**Safe distance from the light source is 14 metres.**

The cooling openings should never be covered with cloth or other materials, and never must be blocked.

This fixture should not be placed in a built-in installation unless proper ventilation is provided.

Only operate the fixture after having checked that the housing is firmly closed and all screws are tightly fastened.

Always use a secondary safety wire when rigging this fixture.

Make sure that the area below the installation place is blocked when rigging, derigging or servicing the fixture.

The fixture becomes very hot during operation. Allow the fixture to cool approximately 20 minutes prior to manipulate with it.

Operate the fixture only after having familiarized with its functions. Do not permit operation by persons not qualified for operating the fixture. Most damages are the result of unprofessional operation!

Please use the original packaging if the fixture is to be transported.

Please consider that unauthorized modifications on the fixture are forbidden due to safety reasons!

If this device will be operated in any way different to the one described in this manual, the product may suffer damages and the guarantee becomes void. Furthermore, any other operation may lead to dangers like short-circuit, burns, electric shock, crash etc.

Immunity of the equipment is designed for electromagnetic environments E1, E2, E3 according to the standard EN55103-2 ed.2 Electromagnetic compatibility. Product family standard for audio, video, audiovisual and entertainment lighting control apparatus for professional use. Part 2: Immunity.

The product (covers and cables) must not be exposed to a high frequency electromagnetic field higher than 3V/m.

The installation company should check levels of possible interferences above the tested levels E1,E2,E3 given by this standard (e.g. transmitters in surrounding area) before installing the equipment.

Emission of the equipment complies with the standard EN55032 Electromagnetic compatibility of multimedia equipment – Emission Requirements according to class B.

**To avoid damage of the internal optical system of the fixture, never let the sunlight or other fixture lights directly to the front lens , even when the fixture is not working !**

## 2. Fixture exterior view

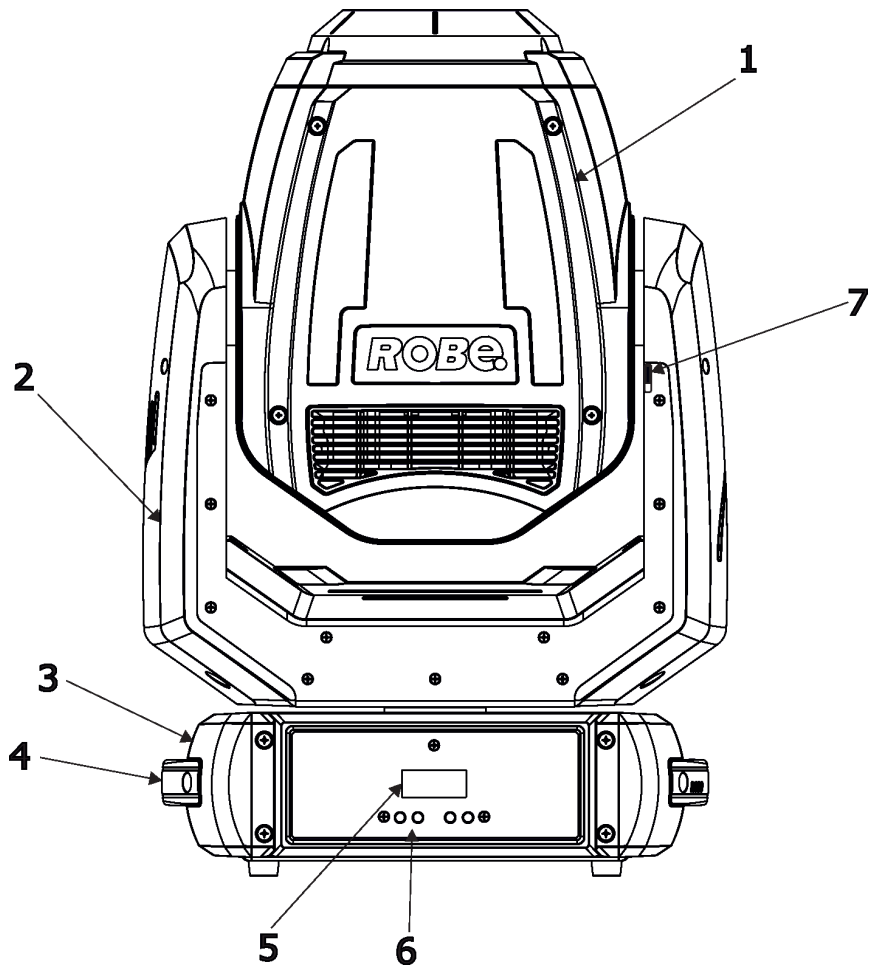

Rear panel of the base

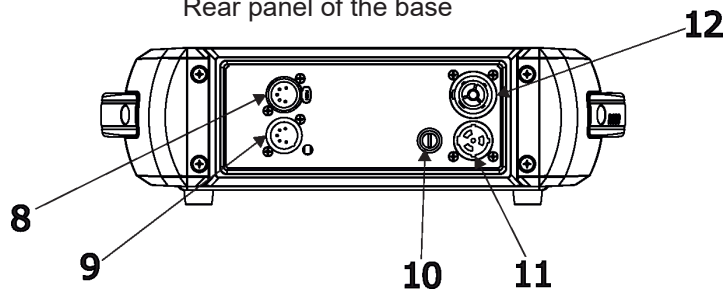

Rear panel of the base -EP version

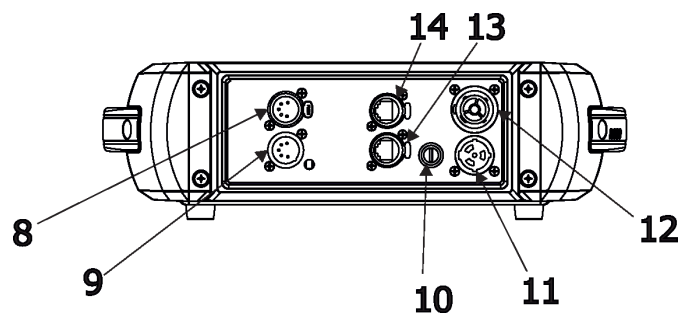

- |                     |                                     |
|---------------------|-------------------------------------|
| 1- Moving head      | 8 - DMX OUT                         |
| 2 - Yoke            | 9 - DMX IN                          |
| 3 - Base            | 10 - Fuse holder                    |
| 4 - Handle          | 11 - Mains IN                       |
| 5 - Display         | 12 - Mains OUT                      |
| 6 - Control buttons | 13 - Ethernet OUT (EP version only) |
| 7 - Tilt lock       | 14 - Ethernet IN (EP version only)  |

### 3. Installation



**Fixtures must be installed by a qualified electrician in accordance with all national and local electrical and construction codes and regulations.**

#### 3.1 Connection to the mains

**For protection from electric shock, the fixture must be earthed!**

The Robin Cuete is equipped with auto-switching power supply that automatically adjusts to any 50-60Hz AC power source from 100-240 Volts.

If you need to install a power plug on the power cable to allow connection to power outlets, install a ground-ing-type (earthed) plug following the plug manufacturer's instructions. If you have any doubts about proper installation, consult a qualified electrician.

Core (EU)	Core (US)	Connection	Plug Terminal Marking
Brown	Black	Live	L
Light blue	White	Neutral	N
Yellow/Green	Green	Earth	

This device falls under class one and must be earthed (grounded)!

The fixture head has to be locked for transportation - the tilt lock latch (7) has to be in the locked position. To unlock the head, move the latch to unlock position before operating the fixture.

Design of the Robin Cuete allows to connect several fixtures to AC mains power in one interconnected dai-sy chain using power input and throughput connectors. Needed daisy chain cords are stated in the chapter "Technical specifications "

The max. number of connected fixtures depends on the AC mains power voltage and fixture version:

CE:

16 fixtures at power supply= 230V

14 fixtures at power supply= 208V

8 fixtures at power supply= 120V

cETLus:

9 fixtures at power supply= 230V

8 fixtures at power supply= 208V

5 fixtures at power supply= 120V

Actual numbers of fixtures may differ from values stated above as you have to take into account the length of supply cables, circuit breaker etc. at projecting of the fixtures installation Do not overload the supply line and the connecting leads.

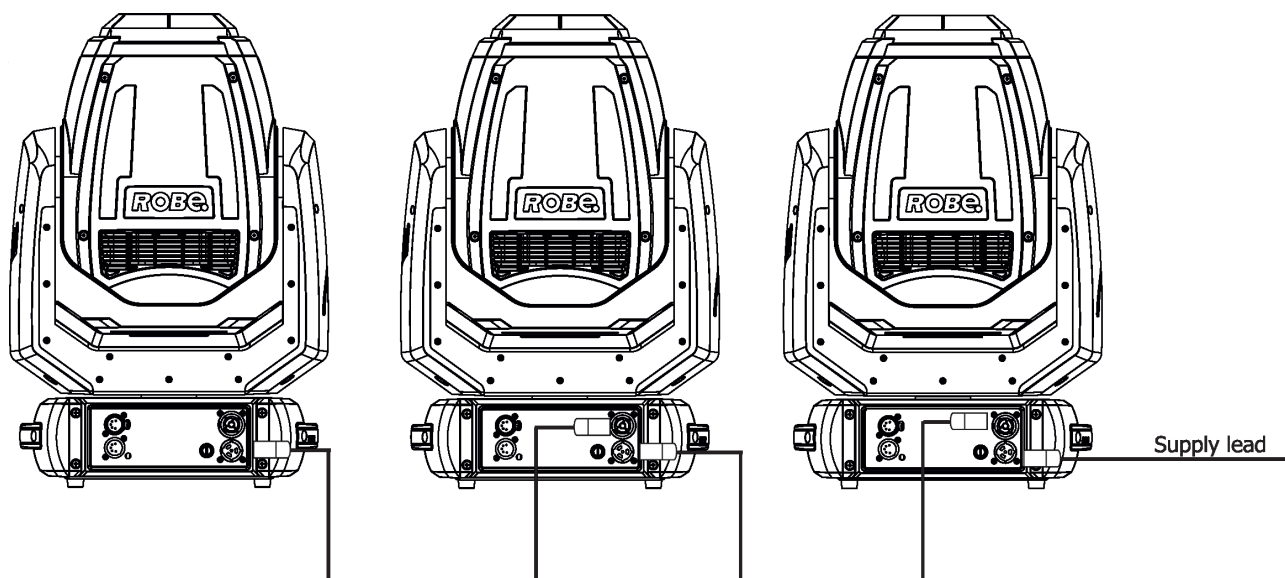

### 3.2 Rigging the fixture

A structure intended for installation of the fixture (s) must safely hold weight of the fixture(s) placed on it. The structure has to be certificated to the purpose.

The fixture (fixtures) must be installed in accordance with national and local electrical and construction codes and regulations.

**For overhead installation, the fixture must be always secured with a safety wire that can bear at least 10 times the weight of the fixture.**

When rigging, derigging or servicing the fixture staying in the area below the installation place, on bridges, under high working places and other endangered areas is forbidden.

The operator has to make sure that safety-relating and machine-technical installations are approved by a skilled person once a year.

The fixture should be installed outside areas where persons may walk by or be seated.

**IMPORTANT! OVERHEAD RIGGING REQUIRES EXTENSIVE EXPERIENCE**, including (but not limited to) calculating working load limits, installation material being used, and periodic safety inspection of all installation materials and the fixture. If you lack these qualifications, do not attempt the installation yourself, but instead use a professional structural rigger. Improper installation can result in bodily injury or damage to property. The fixture has to be installed out of the reach of people.

The fixture must never be fixed swinging freely in the room.

**Caution:** Fixture may cause severe injuries when crashing down! If you have doubts concerning the safety of a possible installation, do not install the moving head!

Before rigging make sure that the installation area can hold a minimum point load of 10 times the fixture's weight.

**When installing the device, make sure there is no highly inflammable material (decoration articles, etc.) in a distance of min. 0.4 m.**

**CAUTION!**  
**Use an appropriate clamps to rig the fixture on the truss.**  
**Make sure that the device is fixed properly! Ensure that the structure (truss) to which you are attaching the fixture is secure.**

The fixture can be placed directly on the stage floor or rigged in any orientation on a truss without altering its operation characteristics .

For securing the fixture to the truss, install a safety wire which can hold at least 10 times the weight of the fixture. Use only the safety wire with a snap hook with screw lock gate.

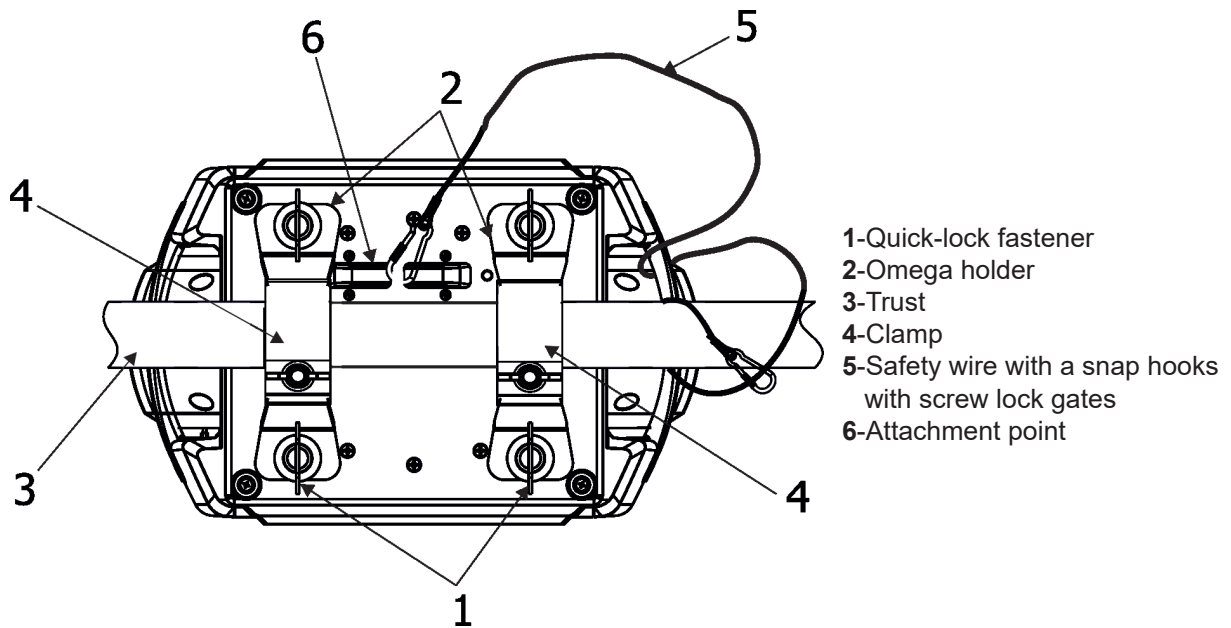

**Truss installation**

1. Bolt each clamp (1) to the omega holder (2) with M12 bolt and lock nut through the hole in the holder.
2. Fasten the omega holders to the bottom of the base by inserting both quick-lock fasteners (1) into the holes of the base and tighten fully clockwise.
3. Clamp the fixture on a truss (3) and tighten the rigging clamps.
4. Pull a safety wire (5) through the carrying handle and the truss (3) as shown on the picture above in a suitable position so that the maximum fall of the fixture will be 20 cm. Fasten a snap hook in the attachment point (6). Use only the safety wire with a snap hooks with screw lock gates.

**When installing fixtures side-by-side, avoid illuminating one fixture with another!**



### 3.3 DMX-512 connection

The fixture is equipped with 5-pin XLR sockets for DMX input and output. Only use a shielded twisted-pair cable designed for RS-485 and 5-pin XLR-plugs and connectors in order to connect the controller with the fixture or one fixture with another.

#### DMX output

XLR socket:



- 1 - Shield
- 2 - Signal (-)
- 3 - Signal (+)
- 4 - Used for wireless DMX
- 5 - Used for wireless DMX

#### DMX input

XLR plug:



- 1 - Shield
- 2 - Signal (-)
- 3 - Signal (+)
- 4 - Used for wireless DMX
- 5 - Used for wireless DMX

If you are using the standard DMX controllers, you can connect the DMX output of the controller directly with the DMX input of the first fixture in the DMX-chain. If you wish to connect DMX-controllers with other XLR-outputs, you need to use adapter-cables.

#### Building a serial DMX-chain:

Connect the DMX-output of the first fixture in the DMX-chain with the DMX-input of the next fixture. Always connect one output with the input of the next fixture until all fixtures are connected. Up to 32 fixtures can be interconnected.

**Caution:** At the last fixture, the DMX-cable has to be terminated with a terminator. Solder a 120  $\Omega$  resistor between Signal (-) and Signal (+) into a 5-pin XLR-plug and plug it in the DMX-output of the last fixture.

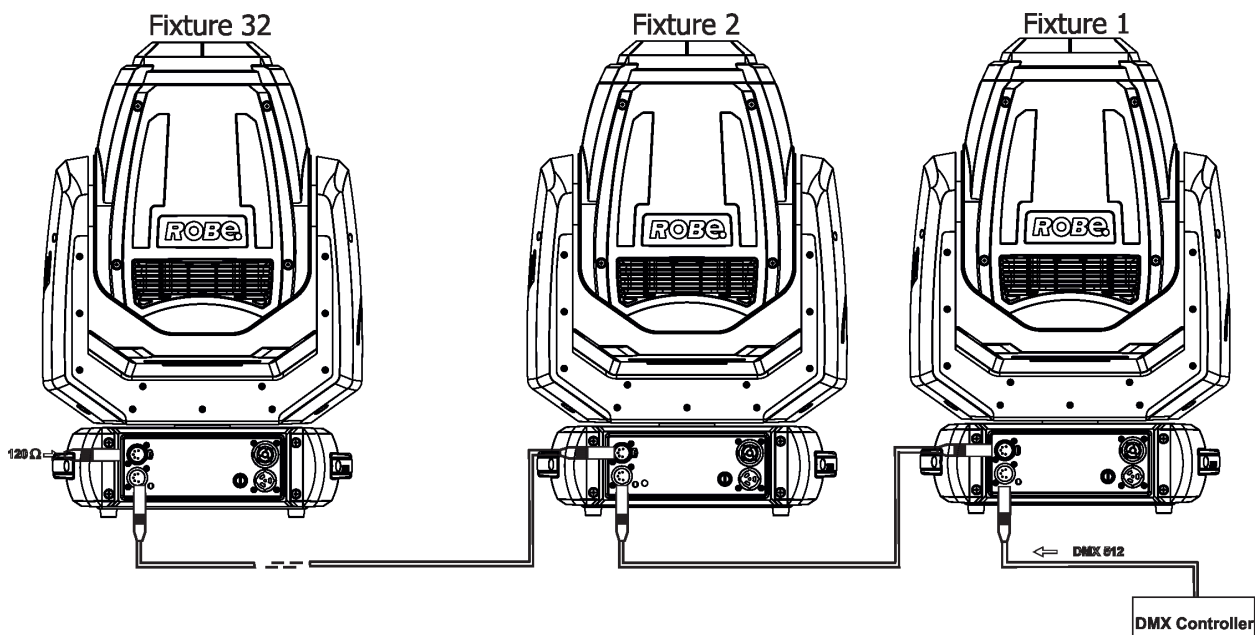

### 3.4 Ethernet connection (EP version only)

The fixtures on a data link are connected to the Ethernet with appropriate communication protocol (e.g. ArtNet). The control software running on your PC (or light console) has to support this communication protocol. Art-Net communication protocol is a 10 Base T Ethernet protocol based on the TCP/IP. Its purpose is to allow transfer of large amounts of DMX 512 data over a wide area using standard network technology.

**The IP address** is the Internet protocol address. The IP uniquely identifies any node (fixture) on a network.  
**The Universe** is a single DMX 512 frame of 512 channels.

The Robin Cuete EP is equipped with 8-pin RJ-45 sockets for Ethernet connection. Use a network cable category 5 (with four "twisted" wire pairs) and standard RJ-45 plugs in order to connect the fixture to the network.

**RJ-45 socket (front view):**

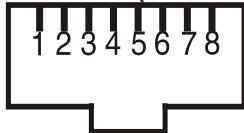

- |                  |                  |
|------------------|------------------|
| 1- TD+           | 5- Not connected |
| 2- TD-           | 6- RX-           |
| 3- RX+           | 7- Not connected |
| 4- Not connected | 8- Not connected |

**RJ-45 plug (front view):**

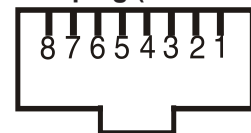

Patch cables that connect fixtures to the hubs or LAN sockets are wired 1:1, that is, pins with the same numbers are connected together:

- |     |     |     |     |     |     |     |     |
|-----|-----|-----|-----|-----|-----|-----|-----|
| 1-1 | 2-2 | 3-3 | 4-4 | 5-5 | 6-6 | 7-7 | 8-8 |
|-----|-----|-----|-----|-----|-----|-----|-----|

If only the fixture and the computer are to be interconnected, no hubs or other active components are needed. A cross-cable has to be used:

- |     |     |     |     |     |     |     |     |
|-----|-----|-----|-----|-----|-----|-----|-----|
| 1-3 | 2-6 | 3-1 | 4-8 | 5-7 | 6-2 | 7-5 | 8-4 |
|-----|-----|-----|-----|-----|-----|-----|-----|

Connect the Ethernet inputs of all fixtures to the Ethernet network. Set their IP addresses and Net Masks. Correct communication protocol (e.g. "ArtNet") has to be selected from the menu "Eth Mode" in the fixtures (Pers-->Ethernet -->Eth Mode). Set Universe(s) according to communication protocol.

Example of connection:

(DMX address=204)  
 IP address=002.168.002.008  
 Universe=1

(DMX address=59)  
 IP address=002.168.002.004  
 Universe=1

(DMX address=30)  
 IP address=002.168.002.003  
 Universe=1

(DMX address=1)  
 IP address=002.168.002.002  
 Universe=1

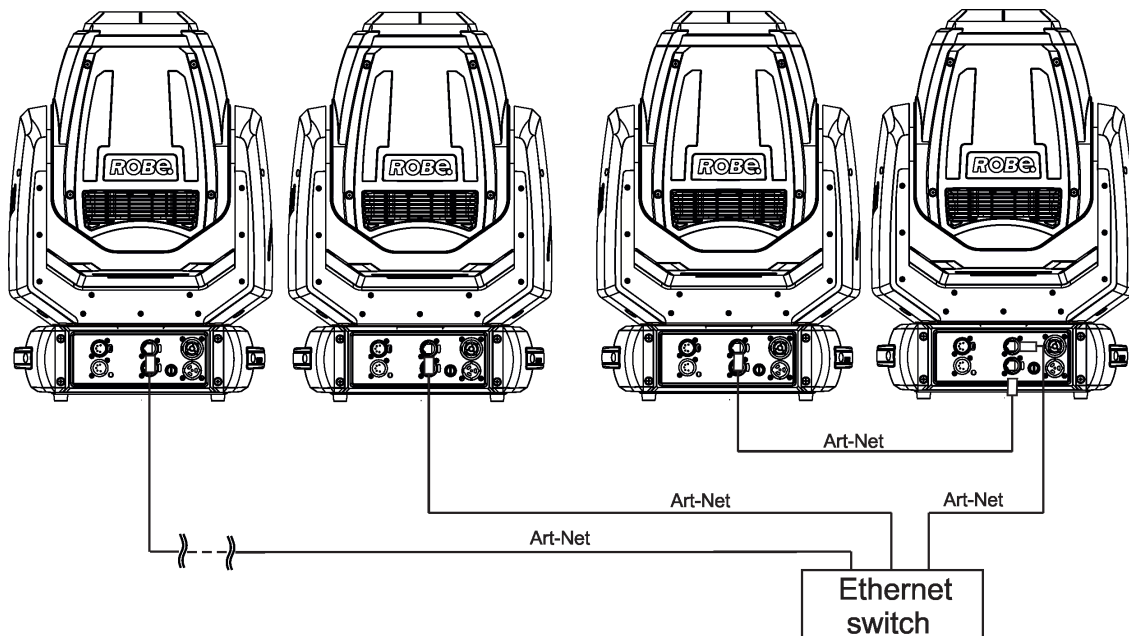

An advised PC setting: IP address: 002.xxx.xxx.xxx (Different from fixtures IP addresses)  
 NET mask: 255.0.0.0

The EP version of the fixture is equipped with Ethernet Pass Through Switch which sustains Ethernet integrity, when the fixture has no power, it automatically maintains network connectivity.

If you use the Ethernet IN-OUT way for the Ethernet connection, max. 8 fixtures can be connected in the IN-OUT line.

### 3.5. Wireless DMX operation

The external ROBE Wireless CRMX Dongle for compact ROBIN fixtures allows receiving wireless DMX. This module is equipped with the Lumen Radio CRMX module and antenna for receiving DMX signal. CRMX module operates on the 2.4 GHz band.

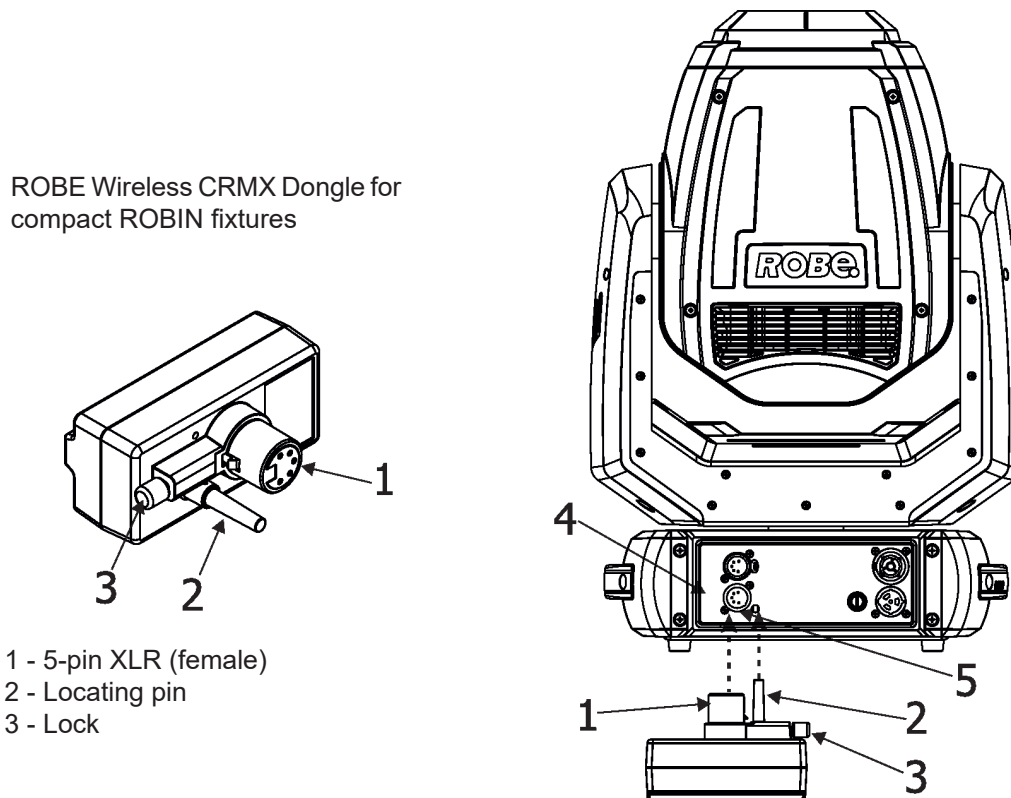

Push in the 5-pin XLR plug (1) into 5-pin XLR socket (4) and simultaneously locating pin (2) into the hole (5) in the front panel of the fixture. In this way the wireless DMX module is connected with the fixture.

NOTE: when you disconnect the DMX wireless module from fixture, press and hold the lock (5) during getting the wireless module out from the 5-pin XLR socket (4) .

#### To link the fixture to a DMX transmitter.

The fixture can be only linked to a transmitter by running the link procedure at DMX transmitter .

After linking , the level of DMX signal ( 0-100 %) is displayed in the menu item “Stat” (Special -->Wireless -->Stat).

#### To unlink the fixture from DMX transmitter.

The fixture can be unlinked from transmitter via the menu item “ Unlink” (Special-->Wireless -->Unlink).

### 3.6. Wide-angle lens installation

**Disconnect the fixture from mains before the wide-angle module installing.**

To install the wide-angle lens

1. Unscrew the four screws (2) to remove the front cover (1) of the head.
2. Unscrew the three screws (3) and remove the covering glass. (4).
3. Place the wide-angle lens (5) on the head and screw it by means of the three screws (3).

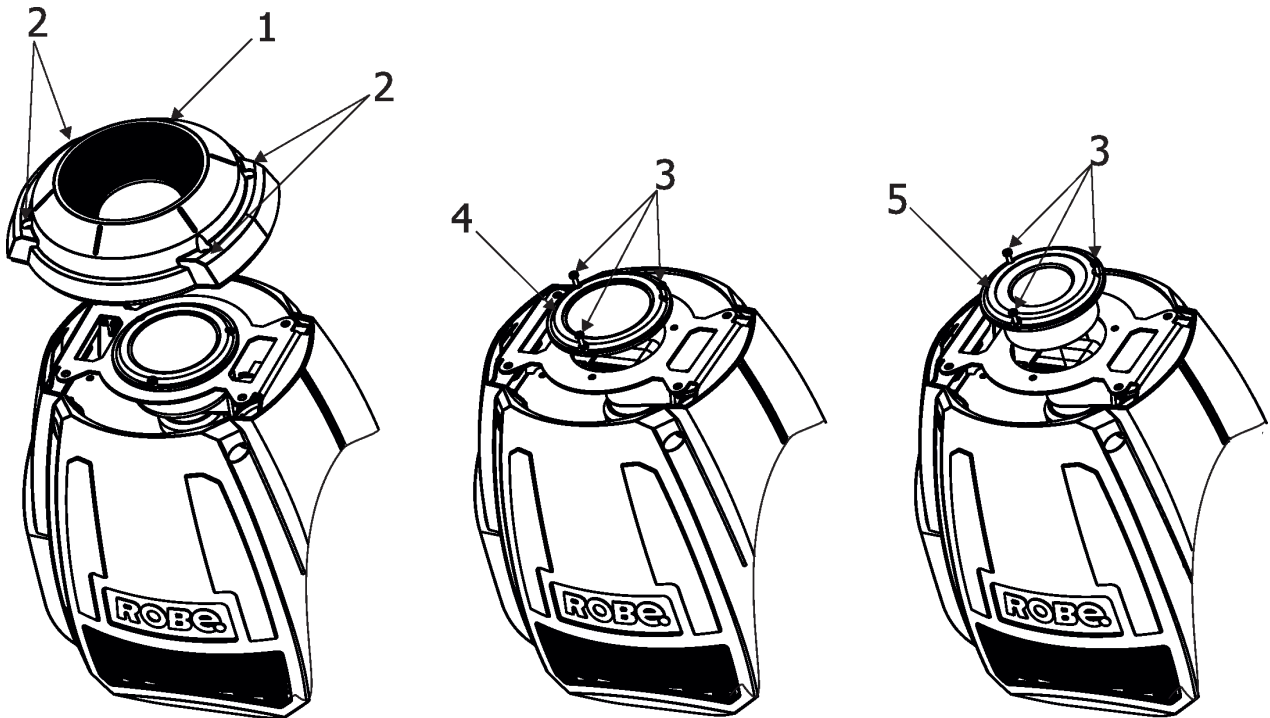

### 3.7. Replacing rotating gobos

**Disconnect the fixture from mains before gobo replacing.**

1. Disconnect the fixture from mains and allow it to cool.
2. Remove the plastic cover of the head by loosening the 4 quarter-turn fasteners on the cover.
3. Gently pull up the gobo holder from the rotation gobo wheel.
4. Carefully remove the spring gobo-lock and gobo from the gobo holder. Do not touch the surface of the pattern of the glass gobo - use a suitable glove. Be careful! Glass gobo!
5. Insert the new gobo (glazy side towards the LED source). Insert the spring-gobo lock to secure it in the gobo holder.
6. Insert the gobo holder back into rotating gobo wheel.
7. Replace the head cover before applying power.

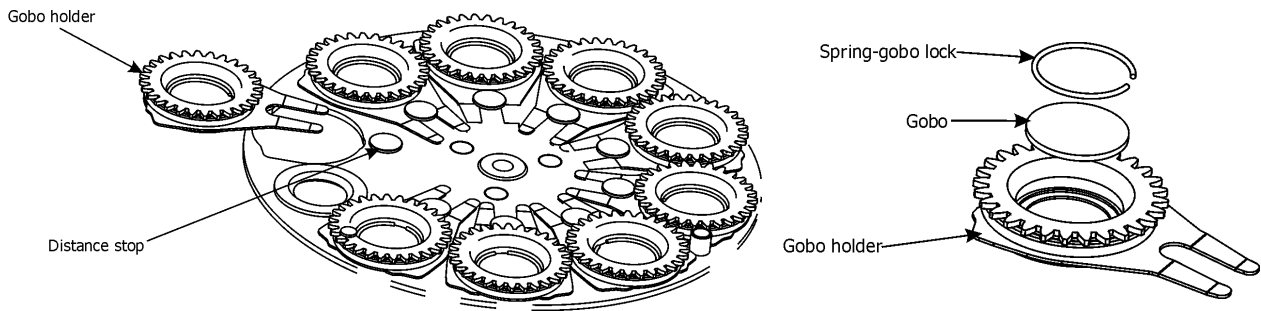

## 4. Remotely controllable functions

### Colour wheel

The colour wheel with 13 dichroic filters rotates in both directions with variable speed which creates wide spectrum of graphic effects.

### CMY colour mixing system

The CMY color mixing system is based on graduated cyan, magenta, and yellow colour filters. A continuous range of colors may be achieved by varying the amount of each filter from 0 to 100%.

### Rotating gobo wheel

The rotating gobo wheel includes 9 glass gobos rotating in both directions, indexable, replaceable "SLOT&LOCK" system.

### Static gobo wheel

The static gobo wheel includes 6 metal gobos and 4 beam reducers. Gobo positioning and continual gobo positioning is available as well as a gobo-shake function.

### Prism

The 8-facet radial prism rotates in both directions at different speeds.

### Frost filter

The 5°frost filter provides variable frost for fine frosting.

### Focus

Motorized focus allows to focus beam from approx. 2 meters to infinity.

### Dimmer/Shutter unit

Smooth 0 - 100 % dimming is provided by the electronic control unit. This unit is also used for strobe effects with variable speed.

### Pan/Tilt

Pan/tilt movement range: 540°/270°

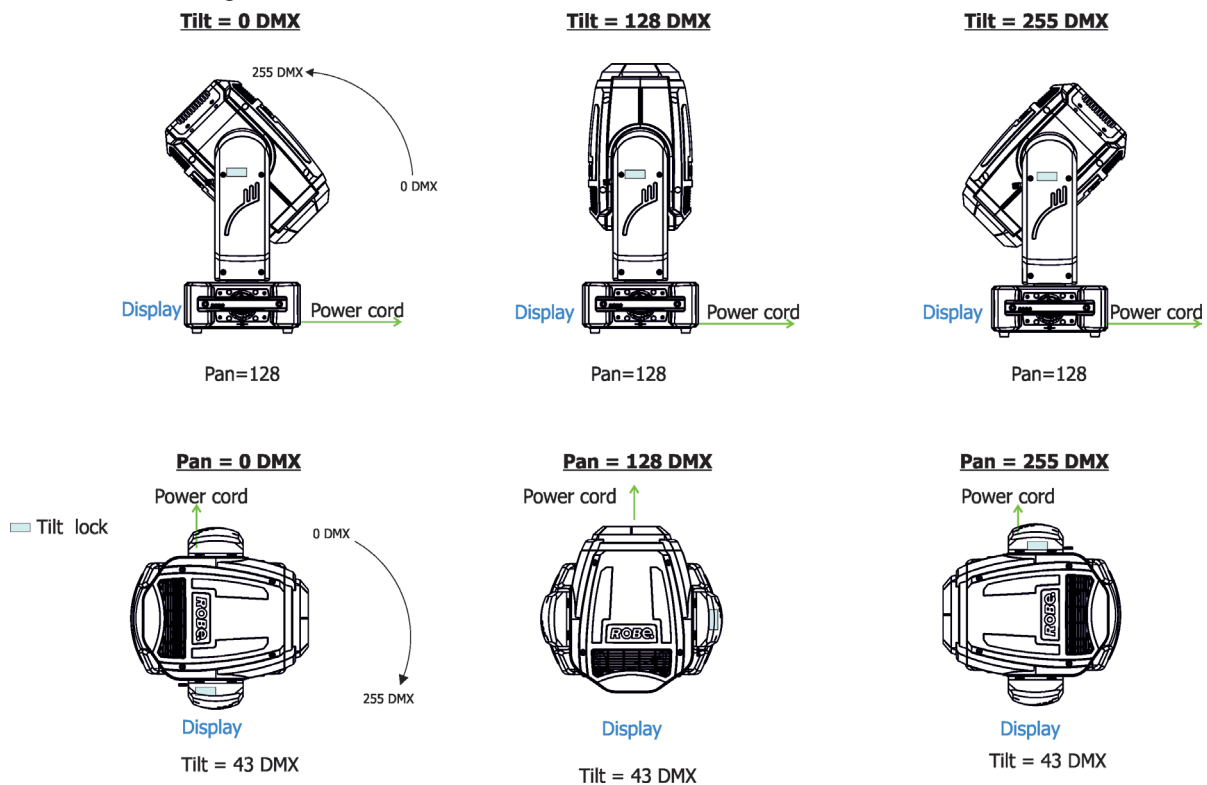

## 5. Control menu map

Default settings=**Bold print**

Level 1	Level 2	Level 3	Level 4	Level 5	Level 6	Level 7
<b>DMXA</b>	Set DMXA	001-512				
	DMX Pres	Mode 1				
	IP Addr*	Def addr	Apply			
		Cus addr	IP 1	0-255		
			IP 2	0-255		
			IP 3	0-255		
			IP 4	0-255		
			Set Address			
		Net Mask*	N.M. 1	0-255		
			N.M. 2	0-255		
			N.M. 3	0-255		
			N.M. 4	0-255		
			Set Net M.			
<b>Info</b>	IP Addr*	IP A. 1				
		IP A. 2				
		IP A. 3				
		IP A. 4				
	MAC Addr*	MAC A. 1				
		MAC A. 2				
		MAC A. 3				
		MAC A. 4				
		MAC A. 5				
		MAC A. 6				
	POn Time	Total				
		Reset				
	Air fil	Aler P				
		R Ti				
	DMX In	Pan	0-255			
		:				
		Dim F	0-255			
	Hea Temp	Current				
		Highest				
		High Res				
	Sw Ver	IC-1				
	IC-2					
	IC-3					
	IC-4					
	IC-5					
	IC-6					
<b>Pers</b>	Ethernet*	Eth Mode	ArtNet			
			sACN			
			gMA I			
			gMA II			
		ArtNet	Uni	0-255		
		sACN	Uni	1-63999		
		MANet	Uni	1-256		
		MANet	IsIDi	1-32		
		IGMP r	Off, 1-10s			
	Pan Rev	On, <b>Off</b>				
	Tilt Rev	On, <b>Off</b>				
	P/T Mode	<b>Speed</b>				
		Time				

Level 1	Level 2	Level 3	Level 4	Level 5	Level 6	Level 7
	P/T Feed	On, Off				
	Display	Turn				
		On/Off T	On, Off			
		Contrast	0-100%			
		Backlight	0-100%			
	LED Freq.	300				
		<b>600</b>				
		1200				
		2400				
	LED FreF					
	BLC DMC	On, <b>Off</b>				
	BLC Col	On, <b>Off</b>				
	BLC P/T	On, <b>Off</b>				
	Mic Sens	0... <b>10</b> ...19				
	Fans	<b>Auto</b> , High				
	Dimmer C	<b>Square</b> , Linear, S square				
	Temp Uni	°C, °F				
	I Ef Pos	Pan				
		:				
		Dim F				
		Store				
	Defaults					
<b>Manual</b>		Pan	0-255			
		:				
		Dim F	0-255			
<b>Test Prg</b>	Static	Pan	0-255			
		Tilt	0-255			
		Run				
	Dynamic					
<b>Sta Alone</b>	Music T	On, <b>Off</b>				
	Auto Run	<b>Off</b>				
		Test				
		Prog 1				
		Prog 2				
		Prog 3				
	Pr Play	Test Prg				
		Prog 1				
		Prog 2				
		Prog 3				
	Pr Edit	Prog 1	Step 1	Pan		
		Prog 2	:	:		
		Prog 3	Step 40	F.Tim	0-25.5	
				S.Tim	0-25.5	
				COPY		
				Prg En	1-40	
<b>Reset</b>						
<b>Special</b>	RDM Low					
	RDM Hight					
	Wireless	Stat				
		Unlink				
	Adjust	DMX Val	Pan	0-255		



Level 1	Level 2	Level 3	Level 4	Level 5	Level 6	Level 7
			:			
			Dim F	0-255		
		Calib	Cal Mech	Pan C	0-255	
				Tilt C	0-255	
				Col C	0-255	
				Pri C	0-255	
				Fro C	0-255	
				Gob C	0-255	
				GR 1 C	0-255	
				GR 2 C	0-255	
				GR 3 C	0-255	
				GR 4 C	0-255	
				GR 5 C	0-255	
				GR 6 C	0-255	
				GR 7 C	0-255	
				GR 8 C	0-255	
				GR 9 C	0-255	
				Foc C	0-255	
				StG C	0-255	
				Store		
			Cal Load			
	Sw Upd	On, <b>Off</b>				

\* Cuete EP version only

## 6. Control menu

The Robin Cuete is equipped with 2-row LCD display which allows you to set the fixture's behaviour according to your needs, obtain information on its operation, control all range of effects and program it in stand-alone mode.

Control panel:

[ESCAPE] button used to leave the menu without saving changes.

[NEXT] , [PREV] buttons for moving between menu items and for value adjusting.

[ENTER] button used to enter the selected menu (menu item) and to confirm adjusted value.

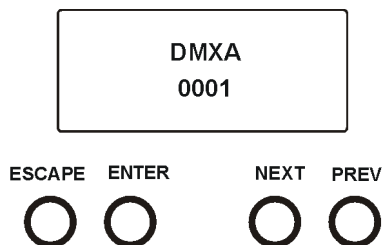

After switching the fixture on, display shows current DMX address.

### 6.1 Addressing (DMXA)

**Set DMXA-** Use this menu item to set the DMX start address of the fixture, which is defined as the first channel from which the Robin Cuete will respond to the controller.

If you set, for example, the address 25, the Robin Cuete will use channels 25 - 53 for control .

Please, be sure that you do not have any overlapping channels in order to control each Robin Cuete correctly and independently from any other fixture on the DMX data link.

If there is no data received at the DMX input, the display will start to flash "0001" with actually stored DMX address.

**P Addr\* - IP address.** Use the menu item to set desired IP address. IP address is the Internet protocol address. The IP uniquely identifies any node (fixture) on a network. There cannot be 2 fixtures with the same IP address on the network!

**Def addr - Default IP address.** This address is derived from fixture's MAC address and cannot be changed. Confirm the item "**Apply**" to select this address.

**Cus addr - Custom address.** IP address consists of four decimal numbers, each ranging from 0 to 255, separated by dots, e.g. 2.16.254.1. Each part represents a group of 8 bits (octet) of the address. The following items "**IP 1**", "**IP 2**", "**IP 3**", "**IP 4**" allow you to set each part (number) of the address.

After setting desired IP address, confirm the item "**Set Address**" to save this address.

**Net Mask\* - Network mask.** Use the menu item to set desired network mask. A network mask is a 32-bit mask used to divide an IP address into subnets and specify the networks available hosts.

The following items "**N. M.1**", "**N.M.2**", "**N.M.3**", "**N.M.4**" serve for setting of each part (number) of net mask. After setting desired network mask, confirm the item "**Set Net M.**" to save adjusted values.

\* Cuete *EP version only*

### 6.2 Fixture information (Info)

**IP Addr\* - IP address.** Select this menu item to read the IP address of the fixture.

**MAC Addr\* -MAC address.** Select this menu item to read the MAC address of the fixture.

\* Cuete *EP version only*

**Pon Time - Power on time.** Select this menu to read the number of fixture operation hours.

**Total** - The item shows the total number of the operation hours since the Robin Cuete has been fabricated.

**Reset** - The item shows the number of the operation hours that the Robin Cuete has been powered on since the counter was last reset.

In order to reset this counter to 0, press and hold both [NEXT] and [PREV] buttons and the [Enter] button at the same time.

**Air fil - Air filter.** Regular cleaning of the air filter in the fixture base is very important for the fixture's life and performance. Build-up of dust, dirt and fog fluid residues reduces the fixture's fan ability.

he two items of this menu help you to keep cleaning period of the air filter.

**Alert P** - Cleaning schedule for the fixture depends on the operating environment.

It is therefore impossible to specify accurate cleaning interval. This item allows you to change the cleaning interval of the air filter. This "alert" value is 300 hours and it is set as default. Inspect the fixture within its 300 hours of operation to see whether cleaning is necessary. If cleaning is required, clean air filter and change the value in this menu on acceptable level. Min. level of alert period is 10 hours, max. is 300 hours.

**R Ti** - The item allows you to read the time which remains to cleaning air filter.

The time period is set in the menu mentioned above.

To reset this menu item press and hold both [NEXT] and [PREV] buttons and the [Enter] button at the same time.

**DMX In - DMX readout.** The menu is used to read DMX values of each channel received by the fixture.

**Hea Temp - Head temperature.** The menu shows temperature on the LEDs PCB in the fixture head.

**Current** - A current temperature of the LEDs PCB.

**Highest** - A maximum temperature of the LEDs PCB since the fixture has been fabricated.

**High Res** - A maximum temperature of the LEDs PCB since the counter was last reset. In order to reset this counter, press and hold both [NEXT] and [PREV] buttons and the [Enter] button at the same time.

**Sw Ver - Software versions.** Select this item to read the software version of the fixture modules.

**IC-1** - A pan/Tilt processor.

**IC-2** - A display processor.

**IC-3** - A LEDs control processor.

**IC-4** - A rot. gobo control processor.

**IC-5** - A prism/frost control processor.

**IC-6** - A CMY control processor

## 6.3 Personality (Pers)

**Ethernet\* - Ethernet settings.** Use the menu item to select and set desired operating mode.

**Ethernet mode** - use the menu to select a protocol.

**Artnet** - fixture will receive Artnet protocol.

**sACN** - fixture will receive sACN protocol.

**gMAI** - fixture will receive MANet 1 protocol.

**gMAII** - fixture will receive MANet 2 protocol.

**ArtNet** - the menu allows you to set parameter for ArtNet operation.

**Uni** - selection of ArtNet Universe (0-255).

**sACN** - the menu allows you to set parameter for sACN operation.

**Uni** - selection of sACN Universe (1-63999).

**MANet** - the menu allows you to set parameters for MANet operation.

**Uni** - selection of MANet Universe (1-63999).

**sID** - selection of the MANet I(II) session ID (1-32)

**IGMP r** - the menu allows you to set repeating time for Internet Group Management Protocol (Off, 1s-10s)

\* Cuete EP version only

**DMX Pres - DMX preset.** Use the menu to select desired channel mode.

**Mode 1** - 29 control channels

**Pan Rev - Pan reverse.** The item allows to invert pan movement.

**Tilt Rev - Tilt reverse.** The item allows to invert tilt movement.

**P/T Mode - Pan and Tilt movement mode.** Use this menu to set mode of the pan/tilt movement.

**Speed** - Both Pan and tilt will move with the same speed as adjusted at the channel "Pan/Tilt speed, Pan/Tilt time".

**Time** – The pan and tilt will move with different speeds and they will come at the same time to the end point of their tracks (pan and tilt use their optimal speeds). Time of the pan/tilt movement (25.5 sec. max.) is set by the channel "Pan/Tilt speed, Pan/Tilt time".

**P/T Feed - Pan and Tilt Feedback.** The menu item allows to return the mowing head to the required pan/tilt position after changing the position by an external force if this option is set on.

Note. The Pan/Tilt Feedback should be permanent On, the option Off is not suitable for standard operation and the head of the fixture can be damaged!

**Display - Display adjusting.** This menu allows you to adjust the display behaviour.

**Turn** - This function rotates menu 180 degrees from current orientation..

**On/Off T** - This function allows you to keep the display permanent on (On/Off T= Off) or turn it off two minutes after last pressing any button on the control panel (On/Off T= On).

**Contrast**- Use this function to adjust contrast of the display (0-100%).

**Backlight**- Use this function to adjust backlight of the display (0-100%).

**Led Freq. - LEDs frequency.** The function allows you to set the PWM (Pulse Width Modulation) output frequency of LEDs to 300Hz, 600Hz, 1200Hz or 2400Hz.

**Led FreF - LEDs frequency fine adjustment.** The menu item allows you fine adjustment of the LED frequency around selected frequency.

**BLC DMC - Blackout during movement correction.** Set this option on if you wish to close light output during the time when the head goes to its correct position, which has been changed by an external force.

**BLC Col - Blackout at colour wheel movement.** The menu item allows to close light output while colours are changing.

**BLC P/T - Blackout at P/T movement.** The menu item allows to close light output while pan/tilt coordinates are changing.

**Mic Sens - Microfon sensitivity.** Enter the menu if you want to adjust the microphone sensitivity ( 0-max., 19-min.).

**Fans - Fan mode.** Use the menu to set the fixture fans to max. fan power mode ("High") or to auto-control mode ("Auto").

**Dimmer C. - Dimmer curve.** Use the menu to select desired dimmer curve: linear ,square law or super square law.

**Temp Uni - Temperature unit.** Use the menu item to change temperature unit from °C to °F.

**I Ef Pos - Init effect positions.** Use the menu to set all effects to the desired positions at which they will stay after switching the fixture on without DMX signal connected.

**Defaults** - The menu item allows to set all fixture parameters to the default (factory) values.

## 6.4 Manual Control (Manual)

Use the menu to control all fixture channels by means of the control panel.

## 6.5 Test program (Test Prg)

Use this menu to to run demo test sequences without an external controller, which will show you some possibilities of using the Robin Cuete.

**Static - Static mode.** This mode is suitable for projections on the wall, ceiling or ground without any head movement.

**Dynamic - Dynamic mode.** This mode uses all Robin Cuete functions including pan/tilt movement and therefore is good for a complete introduction of the fixture.

## 6.6 Stand-alone (St Alone)

**Music T - Music trigger.** Select this function to enable the sound control of the running program via the built-in microphone.

**Auto Run - Presetting playback.** This function allows you to select the program which will be played in the stand-alone mode after switching the fixture on. Selected program will be played continuously in a loop.

**Off** - The option disables „Auto Run” function.

**Test** - The option will start built-in test program.

**Prog 1** - The option will start user-created program 1

**Prog 2** - The option will start user-created program 2

**Prog 3** - The option will start user-created program 3

**Pr Play - Playing program.** Select this menu to run a user-created program in a loop.

**Test Prg** - The option runs built-in test program.

**Prog 1** - The option runs user-created program 1

**Prog 2** - The option runs user-created program 2

**Prog 3** - The option runs user-created program 3

Select the program you wish and press [ENTER]. The selected program starts running. By Pressing [ENTER] again, program pauses running.

**Pr Edit - Editing program.** Select this menu to edit or create the program. The Robin Cuete has one built-in program and one user-editable program up to 40 steps. Each program step has a step time - during which effects last in the current step and a fade time- during which effects move to new positions.

To edit program:

1. Press [NEXT] or [PREV] to select the menu "Edit" and press [ENTER].
2. Press [NEXT] or [PREV] to select the desired program step and press [ENTER] button.
3. Press [NEXT] or [PREV] to select the desired item and press [ENTER] button. Now you can edit by [NEXT] or [PREV] buttons the DMX value (0-255) for selected item:

Prg End.	a total number of the program steps (value 1-40). This value you should be set before starting of programming (e.g. if you want to create program with the 10 steps, set Prg End=10).
PAn	a coarse pan movement
PAn F	a fine pan movement
Tilt	a coarse tilt movement
Tilt F	a fine tilt movement
P/T Sp	a pan/tilt speed
Power	power/special functions
Led Freq	a LED frequency selection
Led FreF	a LED frequency selection (fine)
Max L. in	a max. light intensity indication
Colour	a colour wheel
Colour F	a colour wheel (fine)
Cyan	a cyan flag
Magenta	a magenta flag
Yellow	a yellow flag
Efe Sped	an effect speed
Col. Time	a colour wheel time
Efe Time	a focus/frost/prism time
Stat gob	a static gobo wheel
Gob Whel	a rotating gobo wheel
Rot Gobo	a gobo rotation
Rot Go F	a fine gobo rotation
Prism	a rotating prism
Prism Ro	a prism rotation

Frost	a frost
Focus	a focus
Focus F	a focus (fine)
Stro	a strobe/shutter
Dimm	a dimmer (coarse)
Dim F	a dimmer function (fine)
F.Tim	a fade time (0-25.5 sec)
S.Tim	a step time (0-25.5 sec)
COPY	copying the current prog. step to the next prog. step

4. Press [ENTER] button to confirm adjusted value .
5. Press [ESCAPE] button, select next prog. step, press [ENTER] button and repeat steps 3 - 5).

## 6.7 Reset

This option enables the Robin Cuete to index all effects and return to their standard positions.

## 6.8 Special functions (Special)

**RDM Low** - This menu item shows the first part of the RDM identification code.

**RDM High** - This menu item shows the second part of the RDM identification code.

**Wireless - Stat** - Use the menu to read wireless DMX status.

**Unlink** - use this item to unlink the fixture from a wireless DMX transmitter.

**Adjust - Adjustment**. The menu allows the fine adjustment of effects.

**DMX Val- DMX values**. Use the menu to set DMX values of fixture's channels.

**Calib** - calibration of fixture effects.

**Cal Mech** - Use this menu to calibrate mechanical effects:

- Pan C - a position of the pan
- Tilt C - a position of tilt
- Col C - a position of colour wheel
- Pri C - a position of prism
- Fro C - a position of frost
- Gob C - a carousel of rotating gobos fine movement
- GR1 C - fine movement of the rotating gobo 1
- GR2 C - fine movement of the rotating gobo 2
- GR3 C - fine movement of the rotating gobo 3
- GR4 C - fine movement of the rotating gobo 4
- GR5 C - fine movement of the rotating gobo 5
- GR6 C - fine movement of the rotating gobo 6
- GR7 C - fine movement of the rotating gobo 7
- GR8 C - fine movement of the rotating gobo 8
- GR9 C - fine movement of the rotating gobo 9
- Foc C- fine movement of the focus module
- StG C- fine movement of the static gobo wheel
- Store - saving adjusted values

### *Calibration of effects via the control board*

1. Disconnect DMX controller from the fixture and enter the "Cal Mech" menu.
2. Use the [PREV] and [NEXT] to find "Pan C" and press [ENTER].
3. Set desired value and save it by pressing [ENTER].
4. Repeat steps 2 and 3 for another effects.
5. After calibrating all effects, find the item "Store" and press [ENTER]. to save all adjusted values.

Note: you can also use DMX controller for fine calibration of effects, calibration protocol is the following:

### ***Effect***

Pan	channel 30
Tilt	channel 31

Colour	channel 32
Prism	channel 33
Frost	channel 34
Rot. gobos wheel	channel 35
Gobo 1 rotation	channel 36
Gobo 2 rotation	channel 37
Gobo 3 rotation	channel 38
Gobo 4 rotation	channel 39
Gobo 5 rotation	channel 40
Gobo 6 rotation	channel 41
Gobo 7 rotation	channel 42
Gobo 8 rotation	channel 43
Gobo 9 rotation	channel 44
Focus	channel 45
Static gobo wheel	channel 46

**Cal Load** - the item allows you to load default (factory) calibration.

**Sw Upd - Software update.** The menu item allows you to update software in the fixture.

The following items are required in order to update software:

- PC running Windows or Linux or macOS
- DSU file
- Flash cable RS232/DMX, P/N13050624 (if you want to use a serial port of PC)
- Robe Universal Interface or Robe Universal interface WTX (if you want to use an USB port of PC)

After the software updating the fixture will be set to default values.

To update software in the fixture:

1. DSU file is available from Robe web site at [WWW.robe.cz](http://WWW.robe.cz).  
 File with extension zip is intended for Windows (used and tested from XP to W10 on 32/64bit systems).  
 File with extension tbz is intended for Linux (used and tested on Debian and Ubuntu 32/64bit).  
 File with extension dmg is intended for macOS (used and tested on OSX up to Sierra) XQuartz required, install it from <https://www.xquartz.org/>  
 Save the download file to a folder on your computer.  
 In case that you use windows, extract files in the zip file (e.g. DSU\_RobinCuete\_21091633.zip)
2. Disconnect the fixture from DMX controller.
3. If you use the flash cable RS232/DMX, connect a serial port of your computer with DMX input of the fixture by means of the cable.  
 If you use the Robe Universal Interface, connect a USB port of your computer with the Robe Universal Interface by means of the USB cable and DMX input of the fixture with the DMX output of the Robe Universal Interface via a DMX cable.
4. Switch the fixture to the update mode (Special -> "SW Upd "-> On).  
 Note: If you do not want to continue in the software update, you have to switch off and on the fixture to escape from the updating mode.  
 We recommend to cancel all running programs on your computer before starting the software update.
5. Double-click the software uploader file (e.g. DSU\_RobinCuete\_21091633.exe) in the extracted files. The Software Uploader program will start to run.

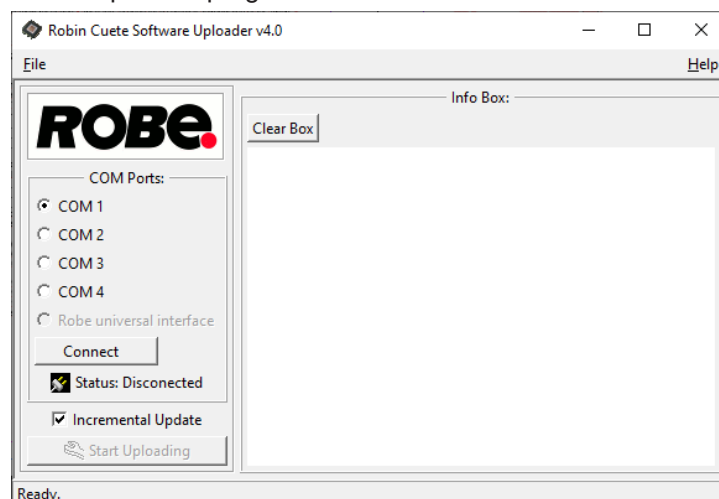



6. Select correct "COM " number if you use a Flash cable RS232/DMX or select "Robe Universal Interface " if you use the Robe Universal Interface/Robe Universal Interface WTX and then click on the "Connect" button.
7. If the connection is OK, click the "Start Uploading" button to start software uploading. It will take several minutes to perform software update.  
 If the option "Incremental Update" is not checked, all processors will be updated (including processors with the same software version).  
 If you wish to update only processors with new version of software, check the "Incremental Update box".  
 Avoid interrupting the process. Update status is being displayed in the "Info Box" window.  
 When the update is finished, the line with the text "Fixture is successfully updated" will appear in this window.
- In case upload process is interrupted (e.g. power loss), the fixture stays in "Updating mode" and you will have to repeat the software update again.

Another way, how to update software in the fixtures (especially large installation of fixtures) is to use the ROBE Uploader. It is a software for automatized software update of Robe fixtures. It takes advantage of RDM support).

For more information please see <https://www.robe.cz/robe-uploader/>.

## 7. RDM

This fixture supports RDM operation. RDM (Remote Device Management) is a bi-directional communications protocol for use in DMX512 control systems, it is the new open standard for DMX512 device configuration and status monitoring.

The RDM protocol allows data packets to be inserted into a DMX512 data stream without adversely affecting existing non-RDM equipment. By using a special „Start Code,“ and by complying with the timing specifications for DMX512, the RDM protocol allows a console or dedicated RDM controller to send commands to and receive messages from specific moving lights.

RDM allows explicit commands to be sent to a device and responses to be received from it.

The list of commands for Robin Cuete is the following.

Parameter ID	Discovery command	SET command	GET command
DISC_UNIQUE_BRANCH	*		
DISC_MUTE	*		
DISC_UN_MUTE	*		
DEVICE_INFO			*
SUPPORTED_PARAMETERS			*
SOFTWARE_VERSION_LABEL			*
DMX_START_ADDRESS		*	*
IDENTIFY_DEVICE		*	*
DEVICE_MODEL_DESCRIPTION			*
MANUFACTURER_LABEL			*
DEVICE_LABEL		*	*
SENSOR_DEFINITION			*
SENSOR_VALUE			*
DISPLAY_INVERT		*	*
DISPLAY_LEVEL		*	*
PAN_INVERT		*	*
TILT_INVERT		*	*
DEVICE_RESET		*	
DMX_PERSONALITY		*	*
DMX_PERSONALITY_DESCRIPTION			*
STATUS_MESSAGES			*
STATUS_ID_DESCRIPTION			*
DEVICE_HOURS			*



PARAMETER_DESCRIPTION			*
ROBE_DMX_INPUT		*	*
ROBE_WIRELESS_UNLINK		*	

RDM model ID for the Robin Cuete is 0x0122.

## 8. Error and information messages

### Tilt Err

This message will appear after the reset of the fixture if the head's indexing circuit malfunctions (sensor failed) or the stepping motor or its driving PCB is defective. The head is not located in the default tilt position after fixture reset.

### Pan Err

This message will appear after the reset of the fixture if the head's indexing circuit malfunctions (sensor failed) or the stepping motor or its driving PCB is defective. The head is not located in the default pan position after fixture reset.

### Focus Err

The message will appear after reset of the fixture if the focus lens is not located in the default position.

### Pr/Fr Err

The message will appear after reset of the fixture if the prism-frost wheel is not in the default position.

### RG C Err

The message will appear after reset of the fixture if the carousel of rotating gobos is not located in the default position.

### RG R Err

The message will appear after reset of the fixture if rotating gobos are not located in the default positions.

### SG R Err

The message will appear after of the fixture if the static gobo wheel is not located in the default position.

### Color Err

The message will appear after reset of the fixture if the colour wheel is not located in the default position.

### Cyan Err

The message will appear after reset of the fixture if the cyan wheel is not located in the default position.

### Magen Err

The message will appear after reset of the fixture if the magenta wheel is not located in the default position.

### Yell Err

The message will appear after reset of the fixture if the yellow wheel is not located in the default position.

### LED 1 Shrt

The message informs you that short circuit has occurred in the LEDs branch 1 of the LEDs PCB.

### LED 2 Shrt

The message informs you that short circuit has occurred in the LEDs branch 2 of the LEDs PCB.

### Clea Air F

The message informs you that cleaning period of the air filter has elapsed and you have to clear air filter in the fixture base and reset the menu item "R Ti".

## **9. Robe Ethernet Access Portal (REAP)**

The REAP allows you to display on your computer information about some fixture settings, operating conditions (e.g. temperature in the fixture) and error messages which were generated during fixture operation. Your computer needs to be connected to the fixture(s) through the means of Ethernet wired network and a network switch.

The Ethernet network connection (Local LAN) typically needs to be set to 2.x.x.x address, assuming that no other computer on the network contains such an address while keeping all ROBE fixtures in default IP settings.

For more information about REAP options, computer and fixture settings please see the REAP user manual at [https://www.robe.cz/res/downloads/user\\_manuals/User\\_manual\\_REAP.pdf](https://www.robe.cz/res/downloads/user_manuals/User_manual_REAP.pdf).

## 10. Technical Specifications

### Electrical

Power supply: electronic auto-ranging  
Input voltage range: 100-240V, 50-60Hz  
Fuse: T 3.15A/250V ~  
Max. power consumption: 220W (power factor 0.96)  
Mains input: CE - max. 16A  
                  ETL - max. 10A  
Mains output: CE - max. 15A  
                  ETL - max. 9A

### Optic

Light source: TE™ 120W White LED Engine (Transferable)  
Colour temperature: 6700K  
CRI: 70  
Typical lumen maintenance: L70/B50 @ 50.000 hours  
Light source warranty: 4 years or 20.000 hours

### Colour wheel

13 dichroic filters + open

### CMY colour mixing

Smooth CMY colour mixing system

### Static gobo wheel

6 metal gobos and 4 beam reducers

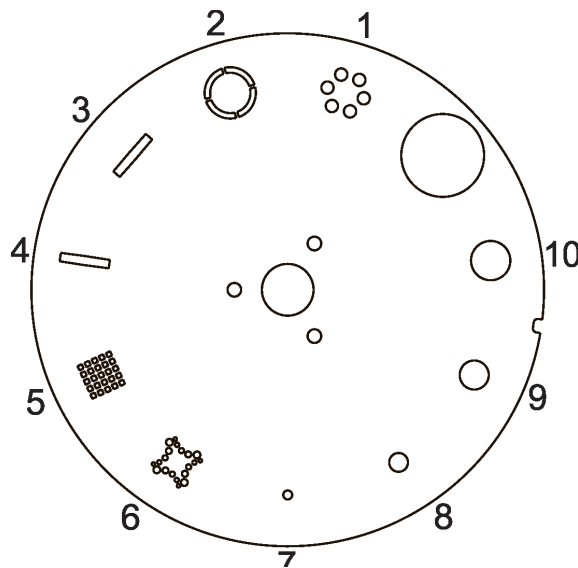

### Rotating gobo wheel

9 glass gobos can be indexed and rotated in both directions at different speeds  
Gobo wheel continuous rotation  
Glass gobos: outside diameter=  $15.8^{+0.15}$  mm, image diameter=12.5 mm, thickness=1.1-1.5 mm,  
high temperature borofloat or better glass  
"Slot&lock" system for easy replacement of gobos

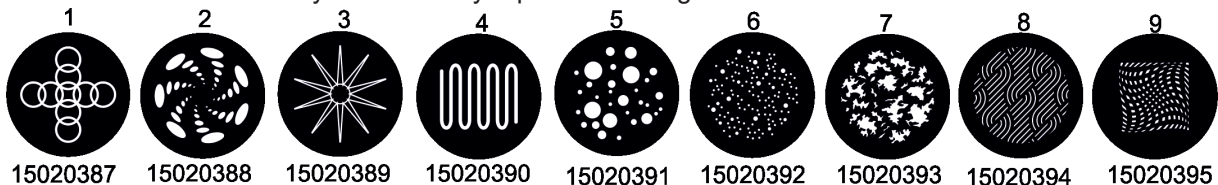

**Prism**

8-facet rotating prism with continuous rotation in both directions

**Frost filter**

Frost filter 5°

**Beam angle**

16° (standard lens)  
22° (wide-angle lens)

**Focus**

Motorized focus allows to focus beam from approx. 2 meters to infinity.

**Strobe**

Strobe effect with variable speed (0.3 - 20Hz)

**Dimmer**

Smooth dimmer from 0 - 100 %

**Pan/Tilt**

Pan movement range 540°  
Tilt movement range 270°  
16 bit movement resolution  
Automatic Pan/Tilt position correction  
Remotely controllable speed of pan/tilt

**Control**

2-row LCD display & 4 buttons  
Readout fixture usage, receiving DMX values, temperatures, etc  
Built-in analyzer for easy fault finding, error messages  
Built-in demo sequences  
Silent fans cooling,  
Stand-alone operation  
3 user editable programs, each up to 40 steps  
Supported protocols: USITT DMX 512, RDM,  
1 DMX mode (29 control channels)

**External Wireless DMX/RDM module (option)**

Compliance with USITT DMX-512 (1986 & 1990) and 512-A  
Full DMX fidelity and frame integrity  
Auto sensing of DMX frame rate and frame size  
<5ms DMX latency  
Operational frequency range of 2402-2480 MHz  
Producer: LumenRadio

**Connection**

DMX data in/out: Locking 5-pin XLR  
Ethernet In/Out: 2 x RJ 45 (Robin Cuete EP only)  
Power IN: Neutrik powerCON TRUE1  
Power OUT: Neutrik powerCON TRUE1

**Max. number of fixtures in Ethernet IN/Out line**

8

**Rigging**

Mounting points: 2 pairs of 1/4-turn locks  
Mounting horizontally or vertically via two Omega holders

## Temperatures

Maximum ambient temperature : 45° C  
Maximum housing temperature : 70° C

## Distances

Min. distance from flammable surfaces: 0.4 m  
Min. distance to lit object: 0.8 m

## Total heat dissipation

max. 560 BTU/h (calculated)

## Protection factor

IP2X

## Weight

12.2 kg

## Dimensions (mm)

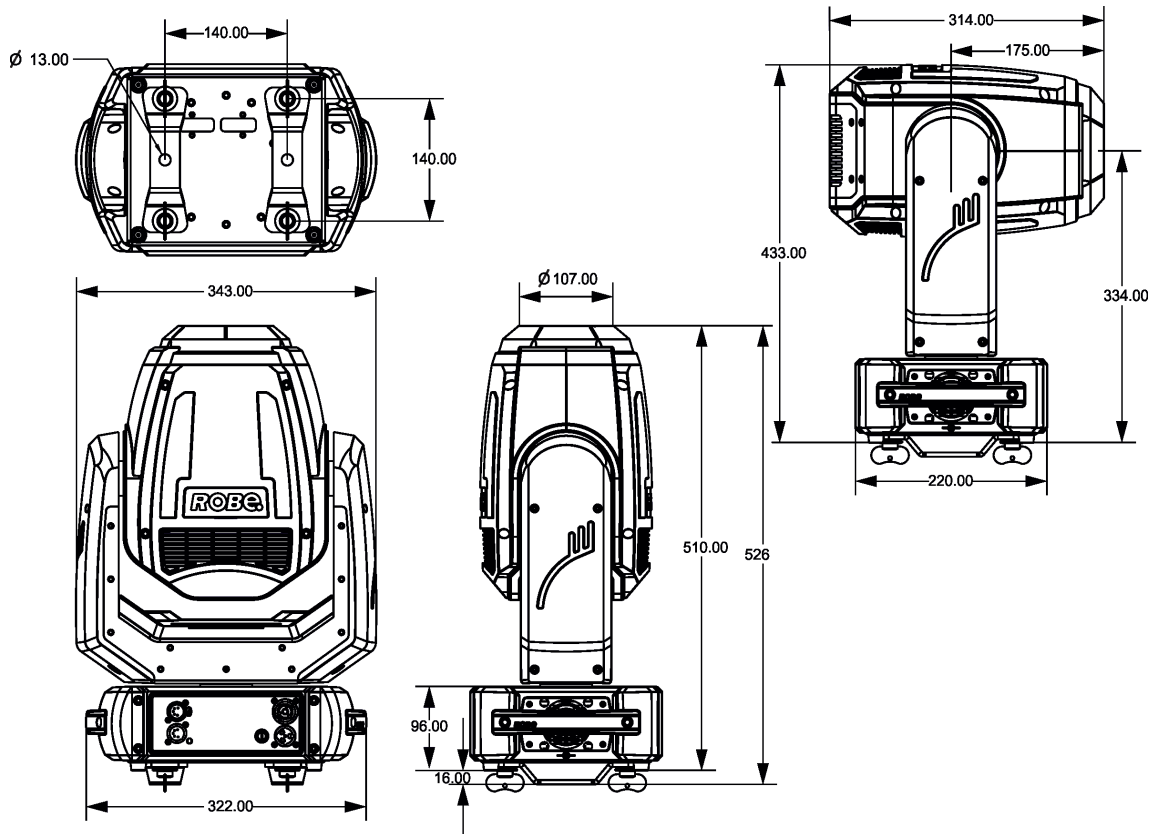

## ROBE Wireless CRMX Dongle for compact ROBIN fixtures

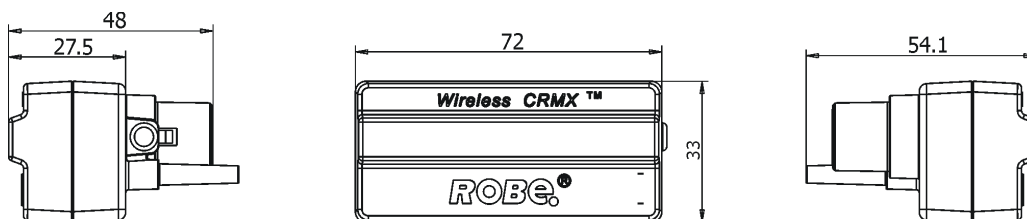

## Accessories

1 x Omega adapter CL-regular 2 pcs in box (P/N 10980033)

## Optional accessories

(P/N 1305 2405) Mains Cable PowerCon In TRUE1/Schuko, 2m, indoor  
(P/N 1305 2406) Mains Cable PowerCon In TRUE1/US, 2m, indoor  
(P/N 1305 2407) Mains Cable PowerCon In TRUE1/open ended, 2m, indoor  
(P/N 13052445) Mains Cable PowerCon In TRUE1/CEE 16A, 2m, indoor  
(P/N 10980127) ROBE Wireless CRMX Dongle for compact ROBIN fixtures  
(P/N 1305 2439) Daisy Chain PowerCon TRUE1 In/Out, EU, 2m, indoor  
(P/N 1305 2440) Daisy Chain PowerCon TRUE1 In/Out, US, 2m, indoor  
(P/N 13052444) Daisy Chain PowerCon TRUE1 In/Out, EU, 5m, indoor  
(P/N 10980033) Omega Adaptor CL-regular 2 pcs  
(P/N 17030386) Doughty Trigger Clamp  
(P/N 99011963) Safety wire 36 kg  
(P/N 10980127) Wireless DMX external module  
(P/N 10980689) Wide angle lens for Robin Cuete black  
(P/N 14080069) TE™HP LED Engine for Cuete

## 11. Maintenance and cleaning

***DANGER !***  
***Disconnect from the mains before starting any  
maintenance work***

**Never use alcohol or solvents for cleaning the front lens and covers of the fixture**

It is absolutely essential that the fixture is kept clean and that dust, dirt and smoke-fluid residues must not build up on or within the fixture. Otherwise, the fixture's light output will be significantly reduced. Regular cleaning will not only ensure the maximum light output, but will also allow the fixture to function reliably throughout its life. A soft lint-free cloth moistened with any good glass cleaning fluid is recommended, under no circumstances should alcohol or solvents be used!

Front lens may require weekly cleaning as smoke-fluid tends to building up residues, reducing the light output very quickly. The cooling fans should be cleaned according to the situation (at least annually). The interior of the head and base should be cleaned at least annually using a vacuum-cleaner.

Periodically clean the air filter placed in the fixture base. This air filter is placed under a grille, which is fastened by means of two magnets.

Use a vacuum cleaner, compressed air or you can wash them and put back dry.

After replacing the air filter, set the remaining time counter in the menu "Fixture Information" (Info--->Air fil. --->R. Ti)

More complicated maintenance and service operations are only to be carried out by authorized distributors.

### 11.1 Replacing the fuse

**Before replacing the fuse, unplug mains lead!**

1. Remove the fuse holder on the rear panel of the base with a fitting screwdriver from the housing (anti-clockwise).
2. Remove the old fuse from the fuse holder.
3. Install the new fuse in the fuse holder (only the same type and rating).
4. Replace the fuseholder in the housing and fix it.

## **11.2 Checking plastic parts of the fixture**

The plastic parts of the fixture should be checked for damages and beginning cracks at least every two months. If hint of a crack is found on some plastic part, do not use the fixture until the damaged part will be replaced. Cracks or another damages of the plastic parts can be caused by the fixture transportation or manipulation and also ageing process may influence plastic materials.

This checking is necessary for both fixed installations and preparing fixtures for renting. Any free moving parts inside of the fixture or any cracked plastic not sitting properly in place need to be immediately replaced.

## **11.3 Disposing of the product**

To preserve the environment please dispose or recycle this product at the end of its life according to the local regulations and codes.

## 12. Photometric diagrams

### Standard lens

Total Output: 4200 lumens

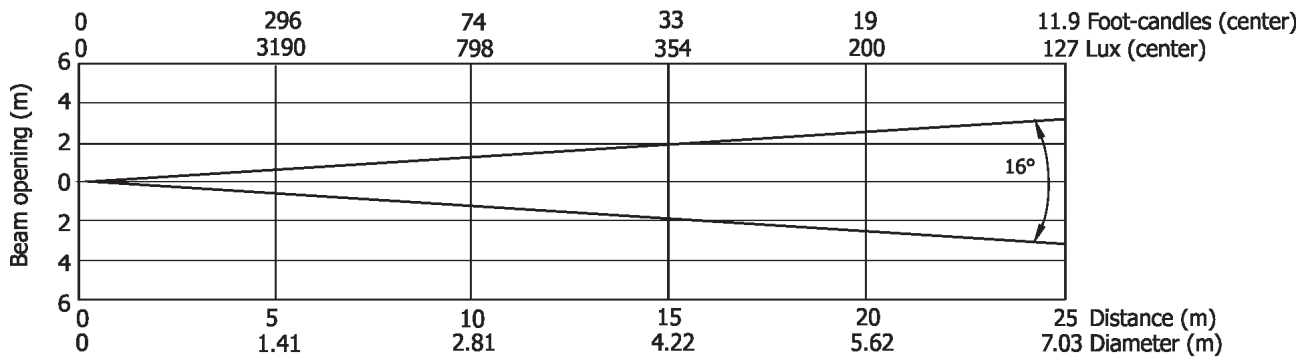

### Wide-angle lens

Total Output: 3878 lumens

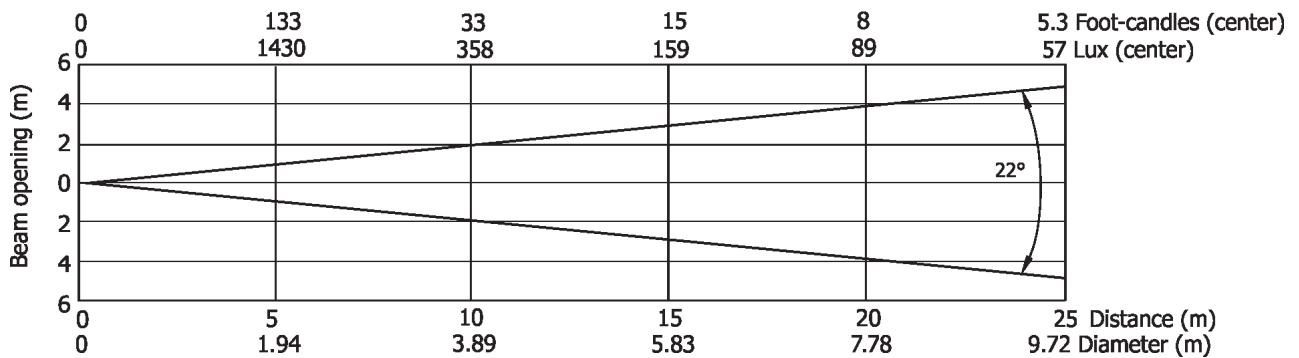



## 13. ChangeLog

This section summarizes changes in the user manual.

Version of the manual	Date of issue	Description of changes
1.1	16/07/2021	Green correction channel removed
1.2	08/10/2021	Software upgrade more specified
1.3	25/11/2021	Optional accessories changed
1.4	16/11/2021	Dimmer curve Super square law added
1.5	24/01/2022	Errorr messages update, EP version added
1.6	16/03/2022	Photometric changed
1.7	08/12/2022	Beam angle changed
1.8	02/02/2023	Chapter REAP added

December 8, 2022

Copyright © 2020-2022 Robe Lighting - All rights reserved

Specifications are subject to change without notice.

Made in ROBE Lighting s.r.o., Palackého 416, 757 01 Valašské Meziříčí, Czech Republic



## 14. Appendix

### 14.1 Changing the LED light source

The Robin Cuete allows you to change the LED light source and this way keep a high performance of the fixture.

To change the LED light source.

1. Disconnect the fixture from mains and allow it to cool about 30 minutes.
2. Remove the top cover of the fixture and lock the head in a horizontal position in which you will have access to the control PCB of the LED light source.
3. Cut off the cable binder (1) and disconnect cables (2) from the fan connector (3) and the LED connector (4) on the control PCB.

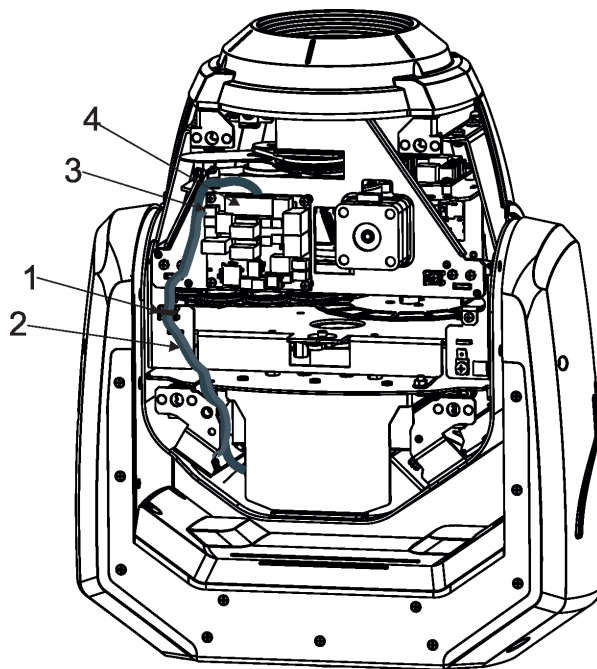

4. Remove the rear cover (5) of the head (10) by unscrewing the four screws M4x10 (6) and disconnect the earthing wire (9).
5. Unscrew the four screws M4x12 (7) and carefully remove the LED module (8) from the head (10).

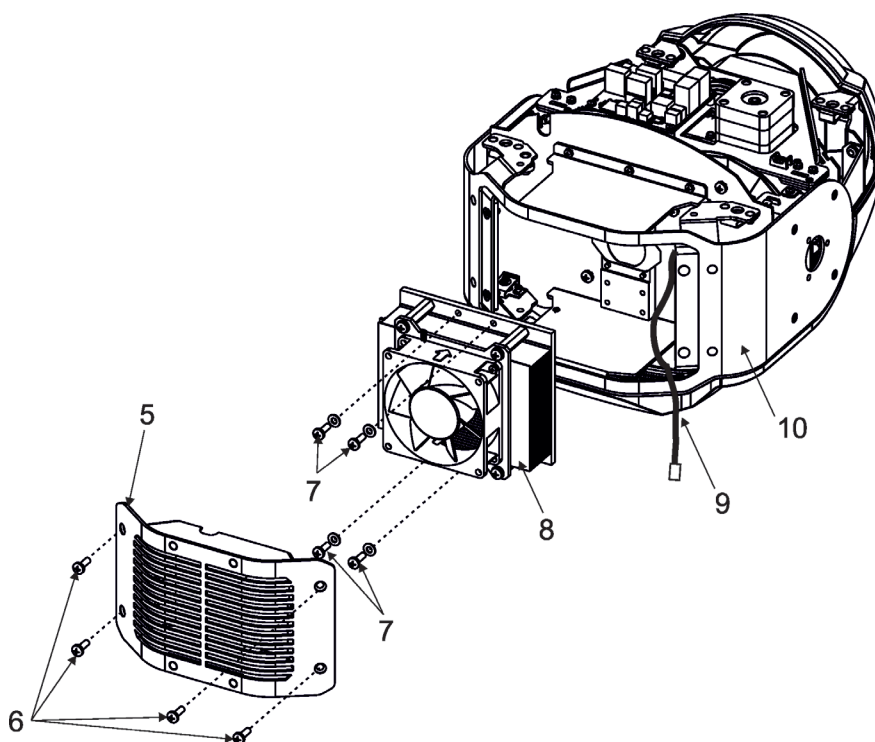

The LED module consists of the LED PCB (A), the heatsink (B) and the Fan (C)

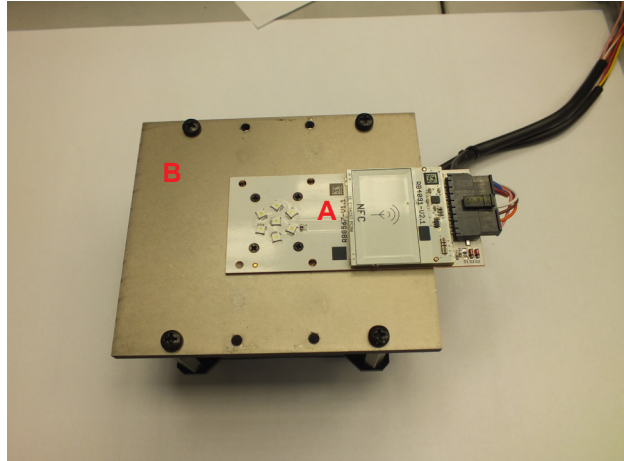
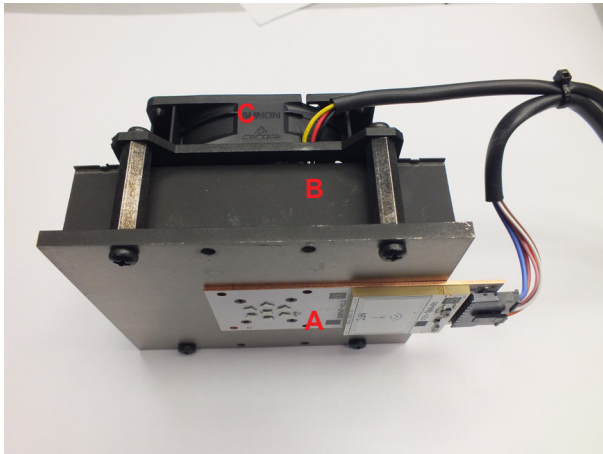

8. Screw the new LED module to the head by means of the four screws M4x12 (7).
9. Connect cables (2) to the control PCB. Fasten the cables to the holder by means of the cable binder (1).
10. Connect the earthing wire (9) to the rear cover (5) and screw this cover to the head by means of the four screws M4x10 (6).
11. Screw the top cover back on the head.

## 14.2. Obtaining information about the LED light source by mobile phone

You can read information about the LED light source by means of the mobile application ROBE COM. The LED light source has to be outside of the fixture.

Download and install the application ROBE COM from Google Play (for Android 5.0 and higher) or App Store (for iOS 12.0 and higher) to your mobile phone. Your mobile phone has to support NFC (Near-Field Communication).

After installing the ROBE COM, run the application by touching the icon  .  
The following screen will appear:

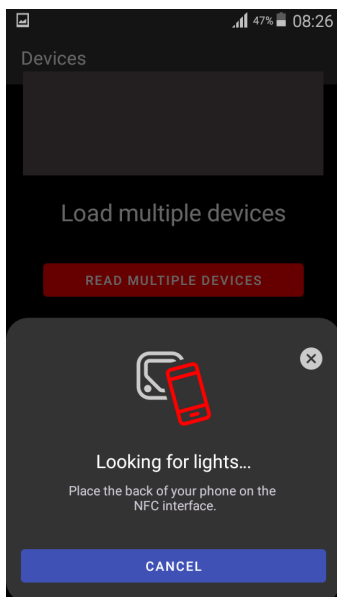

Hold the mobile phone close to the point of the LED PCB which is marked with the symbol NFC.

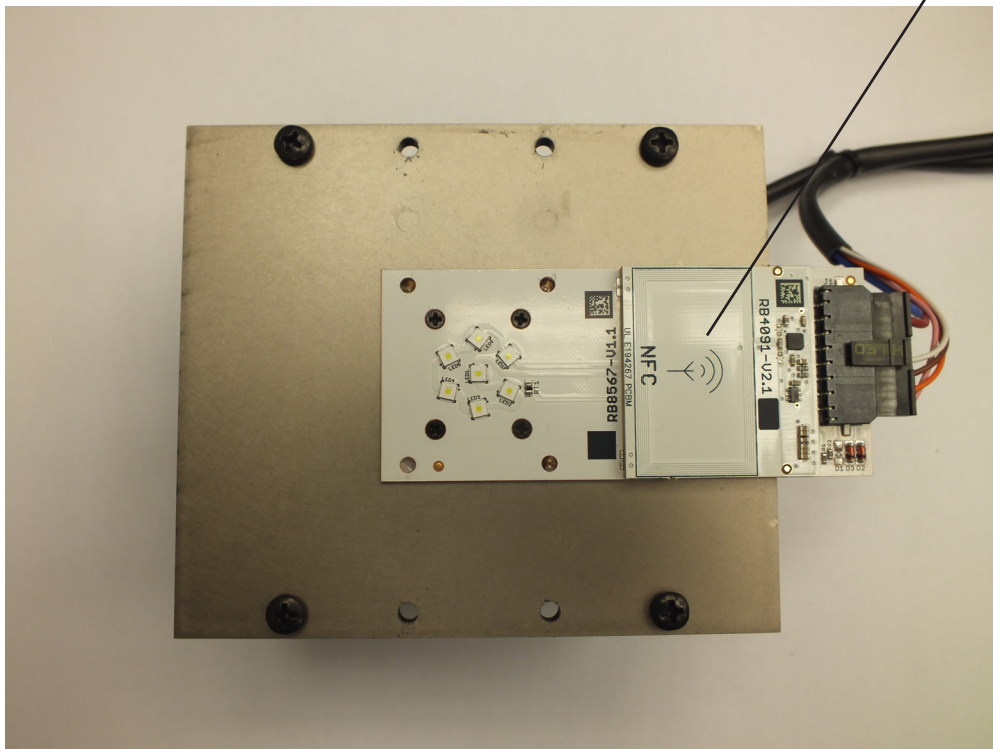

If NFC connection is OK, the following screens will appear.

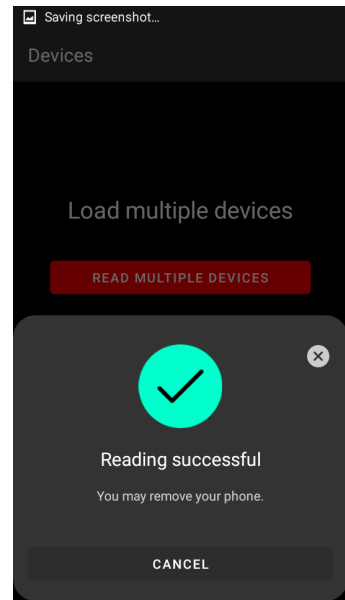
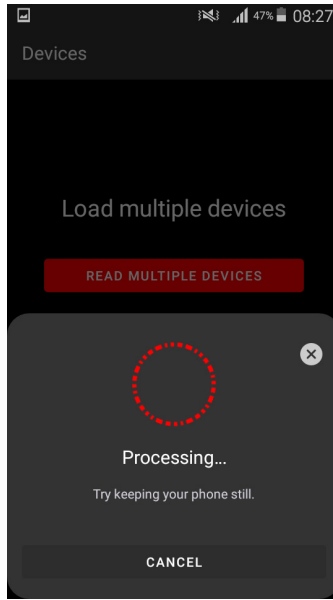
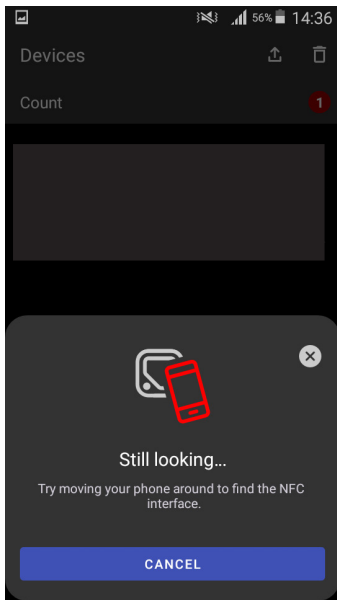

When the following screen will appear, touch the button CANCEL.

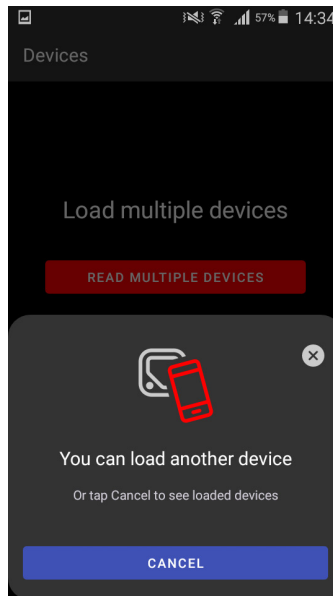

Touch the found LED module ("Robin Cuete LED module") and then touch "LED engine" to read information about found LED module.

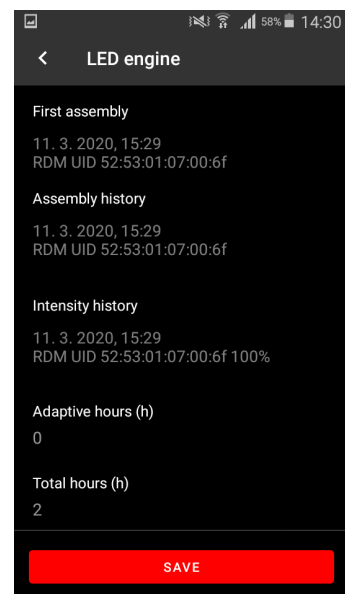
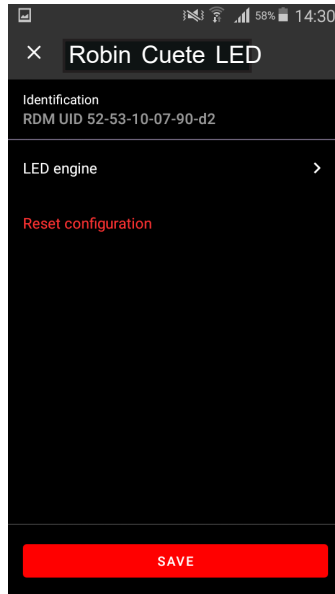
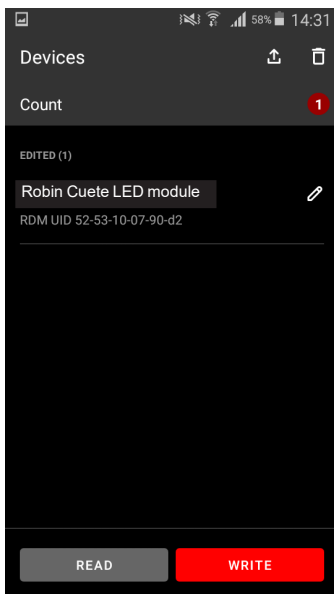

## DMX protocol

Robin Cuete - DMX protocol			
Version 1.3			
Channel	DMX Value	Function	Type of control
1		<b>Pan</b>	
	0 - 255	Pan movement by 540° (128=default)	proportional
2		<b>Pan Fine</b>	
	0 - 255	Fine control of pan movement (0=default)	proportional
3		<b>Tilt</b>	
	0 - 255	Tilt movement by 270° (128=default)	proportional
4		<b>Tilt fine</b>	
	0 - 255	Fine control of tilt movement (0=default)	proportional
5		<b>Pan/Tilt speed , Pan/Tilt time</b>	
	0	Standard mode (0=default)	step
	1	Max. Speed Mode	step
		<b>Pan/Tilt speed mode</b>	
	2 - 255	Speed from max. to min.	proportional
		<b>Pan/Tilt time mode</b>	
	2 - 255	Time from 0.2 s to 25.5 sec.	proportional
6		<b>Power/Special functions</b>	
	0 - 19	Reserved (0=default)	
		<i>To activate following functions, stop in DMX value for at least 3 s and shutter must be closed at least 3 sec. („Shutter,Strobe“ channel 27 must be at range: 0-31 DMX). Corresponding menu items are temporarily overridden.</i>	
	20-24	Display On	step
	25-29	Display Off	step
	30-44	Reserved	
	45-49	Dimmer curve: Super square law	step
	50-54	Dimmer curve: Square law	step
	55-59	Dimmer curve: Linear	step
	60-64	Fans mode: Auto	step
	65-69	Fans mode: High	step
	70-74	Fans mode: Quiet	step
	75-89	Reserved	
	90 - 94	Pan/Tilt speed mode	step
	95-99	Pan/Tilt time mode	step
	100 - 104	Blackout while pan/tilt moving	step
	105 - 109	Disabled blackout while pan/tilt moving	step
	110 - 114	Blackout while colour wheel moving	step
	115 - 119	Disabled blackout while colour wheel moving	step
	120-124	Blackout while gobo wheels moving: On	step
125-129	Disabled blackout while gobo wheels moving: Off	step	
	<i>To activate following functions, stop in DMX value for at least 3 seconds.</i>		
130 - 139	Fixture reset (except pan/tilt)	step	
140 - 149	Pan/Tilt reset	step	
150 - 159	Colour system reset	step	
160 - 169	Gobo wheels reset	step	
170 - 179	Reserved		

DMX protocol

Channel	DMX Value	Function	Type of control
	180 - 189	Focus/frost/prism reset	step
	190 - 199	Reserved	
	200 - 209	Total fixture reset (including pan/tilt)	step
	210 - 218	Reserved	
		The following three commands define way of transition from gobo rotation to gobo indexing:	
	219 - 220	Gobo indexing: Maximum speed and shortcut	step
	221 - 222	Goboindexing: Follow speed and direction	step
	223 - 224	Gobo indexing: Maximum speed and follow direction	step
		The following RoboSpot related commands are only applicable when the RoboSpot is connected:	
	225 - 229	RoboSpot enabled	step
	230 - 234	RoboSpot disabled - except handle faders and pan/tilt	step
	235 - 239	RoboSpot fully disabled	step
	240 - 255	Reserved	
<b>7</b>		<b>LED frequency selection</b>	
		Factory display menu setting: 600Hz	
		<i>Select PWM output frequency of LEDs. Selected PWM frequency can be fine adjusted in 127 steps up/down around selected PWM frequency on the channel below. Corresponding menu item is temporarily overridden.</i>	
	0-4	PWM frequency from Display menu (fixture utilizes PWM frequency set in the display menu item Frequency Setup).	step
	5-9	300 Hz	step
	10-14	600 Hz (10=default)	step
	15-19	1200 Hz	step
	20-24	2400 Hz	step
	25-29	High	step
	30-255	Reserved (fixture utilizes PWM frequency set in the display menu item Frequency Setup).	
<b>8</b>		<b>LED frequency fine adjusting</b>	
		Factory display menu setting: 600Hz	
		<i>Select desired PWM output frequency of LEDs on the channel above.</i>	
	0-1	Selected LED Frequency	step
	2	LED Frequency (step -126)	step
	3	LED Frequency (step -125)	step
	4	LED Frequency (step -124)	step
	:		
	125	LED Frequency (step -3)	step
	126	LED Frequency (step -2)	step
	127	LED Frequency (step -1)	step
	128	Selected LED Frequency (128=default)	step
	129	LED Frequency (step +1)	step
	130	LED Frequency (step +2)	step
	131	LED Frequency (step +3)	step
	:		
	252	LED Frequency (step +124)	step
	253	LED Frequency (step +125)	step
	254	LED Frequency (step +126)	step

DMX protocol

Channel	DMX Value	Function	Type of control
	255	Selected LED Frequency	step
<b>9</b>		<b>Max. light intensity indication and setting</b>	
	0-10	No function (0=default)	
	11-20	Indication of drop of max. light intensity	step
		<i>A drop of max. light intensity of the fixture (compared to its original intensity) is indicated by a corresponding colour output: 0-5%, (WHITE /new LED module/) 6-10% (RED) 11-15% (GREEN) 16-20% (BLUE ) 21-25% (CYAN ) 26-30% (MAGENTA) 31-35% (YELLOW) 36-40% (ORANGE) Pan/tilt is set at 128 DMX (50%), Dimmer is open at 255 DMX (100%).</i>	
		<i>To set a drop of max. light intensity (compared to original light intensity), stay at DMX value for at least 3 sec. and shutter must be closed at least 3 sec. (Channel „Shutter/ Strobe“ 30 must be at range: 0-31 DMX). Corresponding menu items are permanently overwritten.</i>	
	21-30	Set drop by 6-10% (RED)	step
	31-40	Set drop by 11-15% (GREEN)	step
	41-50	Drop by 16-20% (BLUE)	step
	51-60	Set drop by 21-25% (CYAN)	step
	61-70	Set drop by 26-30% (MAGENTA)	step
	71-80	Set drop by 31-35% (YELLOW)	step
	81-90	Set drop by 36-40% (ORANGE)	step
	91-100	Original intensity (WHITE)	step
	101-255	Reserved	
<b>10</b>		<b>Colour wheel</b>	
		<b>Continual positioning</b>	
	0	Open/white	proportional
	9	Deep Red	proportional
	18	Deep Blue	proportional
	27	Yellow	proportional
	37	Light green	proportional
	46	Magenta	proportional
	55	Lavender	proportional
	64	Pink	proportional
	73	Dark green	proportional
	82	CTO 2700K	proportional
	91	Blue	proportional
	101	Orange	proportional
	110	CTO 3200K	proportional
	119	UV (Kongo blue)	proportional
	128-129	White	step
		<b>Positioning</b>	



DMX protocol

Channel	DMX Value	Function	Type of control
	130-134	Deep Red	step
	135-138	Deep Blue	step
	139-143	Yellow	step
	144-147	Light green	step
	148-152	Magenta	step
	153-157	Lavender	step
	158-161	Pink	step
	162-166	Dark green	step
	167-171	CTO 2700K	step
	172-176	Blue	step
	177-180	Orange	step
	181-185	CTO 3200K	step
	186-189	UV (Kongo blue)	step
	190 - 215	Forwards rainbow effect from fast to slow	proportional
	216 - 217	No rotation	step
	218 - 243	Backwards rainbow effect from slow to fast	proportional
	244 - 249	Random colour selection by audio control (Set microphone sensitivity in menu „Personality“)	step
	250 - 255	Auto random colour selection from fast to slow	proportional
<b>11</b>		<b>Colour wheel - fine positioning</b>	
	0 - 255	Fine positioning (0=default)	proportional
<b>12</b>		<b>Cyan</b>	
	0 - 255	Cyan from min. saturation --> full cyan (0=default)	proportional
<b>13</b>		<b>Magenta</b>	
	0 - 255	Magenta from min. saturation --> full magenta (0=default)	proportional
<b>14</b>		<b>Yellow</b>	
	0 - 255	Yellow from min. saturation --> full yellow (0=default)	proportional
<b>15</b>		<b>Virtual colour wheel</b>	
	0	No function (0=default)	step
	1-2	Filter 4 (Medium Bastard Amber)	step
	3-4	Filter 10 (Medium Yellow)	step
	5-6	Filter 19 (Fire)	step
	7-8	Filter 26 (Bright Red)	step
	9-10	Filter 58 (Lavender)	step
	11-12	Filter 68 (Sky Blue)	step
	13-14	Filter 71 (Tokyo Blue)	step
	15-16	Filter 79 (Just Blue)	step
	17-18	Filter 88 (Lime Green)	step
	19-20	Filter 90 (Dark Yellow Green)	step
	21-22	Filter 100 (Spring Yellow)	step
	23-24	Filter 101 (Yellow)	step
	25-26	Filter 102 (Light Amber)	step
	27-28	Filter 103 (Straw)	step
	29-30	Filter 104 (Deep Amber)	step
	31-32	Filter 105 (Orange)	step
	33-34	Filter 106 (Primary Red)	step
	35-36	Filter 111 (Dark Pink)	step
	37-38	Filter 115 (Peacock Blue)	step

DMX protocol

Channel	DMX Value	Function	Type of control
	39-40	Filter 116 (Medium Blue-Green)	step
	41-42	Filter 117 (Steel Blue)	step
	43-44	Filter 118 (Light Blue)	step
	45-46	Filter 119 (Dark Blue)	step
	47-48	Filter 120 (Deep Blue)	step
	49-50	Filter 121 (Filter Green)	step
	51-52	Filter 128 (Bright Pink)	step
	53-54	Filter 131 (Marine Blue)	step
	55-56	Filter 132 (Medium Blue)	step
	57-58	Filter 134 (Golden Amber)	step
	59-60	Filter 135 (Deep Golden Amber)	step
	61-62	Filter 136 (Pale Lavender)	step
	63-64	Filter 137 (Special Lavender)	step
	65-66	Filter 138 (Pale Green)	step
	67-68	Filter 139 (Primary Green)	step
	69-70	Filter 141 (Bright Blue)	step
	71-72	Filter 147 (Apricot)	step
	73-74	Filter 148 (Bright Rose)	step
	75-76	Filter 152 (Pale Gold)	step
	77-78	Filter 154 (Pale Rose)	step
	79-80	Filter 157 (Pink)	step
	81-82	Filter 158 (Deep Orange)	step
	83-84	Filter 162 (Bastard Amber)	step
	85-86	Filter 164 (Flame Red)	step
	87-88	Filter 165 (Daylight Blue)	step
	89-90	Filter 169 (Lilac Tint)	step
	91-92	Filter 170 (Deep Lavender)	step
	93-94	Filter 172 (Lagoon Blue)	step
	95-96	Filter 179 (Chrome Orange)	step
	97-98	Filter 180 (Dark Lavender)	step
	99-100	Filter 181 (Congo Blue)	step
	101-102	Filter 197 (Alice Blue)	step
	103-104	Filter 201 (Full C.T. Blue)	step
	105-106	Filter 202 (Half C.T. Blue)	step
	107-108	Filter 203 (Quarter C.T. Blue)	step
	109-110	Filter 204 (Full C.T. Orange)	step
	111-112	Filter 205 (Half C.T. Orange)	step
	113-114	Filter 206 (Quarter C.T. Orange)	step
	115-116	Filter 247 (Filter Minus Green)	step
	117-118	Filter 248 (Half Minus Green)	step
	119-120	Filter 281 (Three Quarter C.T. Blue)	step
	121-122	Filter 285 (Three Quarter C.T. Orange)	step
	123-124	Filter 352 (Glacier Blue)	step
	125-126	Filter 353 (Lighter Blue)	step
	127-128	Filter 715 (Cabana Blue)	step
	129-130	Filter 778 (Millennium Gold)	step
	131-132	Filter 793 (Vanity Fair)	step
	133-255	Reserved	

DMX protocol

Channel	DMX Value	Function	Type of control
<b>16</b>		<b>CMY and Colour wheel time</b>	
	0	Function is off (0=default)	step
	1 - 255	Time of CMY and Colour wheel movement (0.1sec-->25.5sec.)	proportional
<b>17</b>		<b>Focus/Frost/Prism time</b>	
	0	Function is off (0=default)	step
	1 - 255	Time of focus and frost movement (0.1 sec-->25.5 sec.)	proportional
	1-50	Time of prism movement (0.1 sec-->5 sec.)	proportional
<b>18</b>		<b>Static gobo wheel</b>	
	0-9	Open/hole	step
		<b><u>Positioning</u></b>	
	10-17	Gobo 1	step
	18-25	Gobo 2	step
	26-33	Gobo 3	step
	34-41	Gobo 4	step
	42-49	Gobo 5	step
	50-57	Gobo 6	step
	58-65	Beam reduser 1	step
	66-73	Beam reduser 2	step
	74-81	Beam reduser 3	step
	82-89	Beam reduser 4	step
		<b><u>Shaking gobos from slow to fast</u></b>	
	90-100	Gobo 1	proportional
	101-111	Gobo 2	proportional
	112-122	Gobo 3	proportional
	123-133	Gobo 4	proportional
	134-144	Gobo 5	proportional
	145-155	Gobo 6	proportional
	156-166	Beam reduser 1	proportional
	167-177	Beam reduser 2	proportional
	178-188	Beam reduser 3	proportional
	189-199	Beam reducer 4	proportional
	200-201	Open/hole	step
	202 - 222	Forwards gobo wheel rotation from fast to slow	proportional
	223 - 243	Backwards gobo wheel rotation from slow to fast	proportional
	244 - 249	Random gobo selection by audio control	step
		<i>(Set microphone sensitivity in menu „Personality“)</i>	
	250 - 255	Auto random gobo selection from fast to slow	proportional
<b>19</b>		<b>Rotating gobo wheel</b>	
		<i>Index - set indexing on channel 20</i>	
	0-4	Open/Hole (default)	step
	5-7	Gobo 1	step
	8-10	Gobo 2	step
	11-13	Gobo 3	step
	14-16	Gobo 4	step
	17-19	Gobo 5	step
	20-22	Gobo 6	step
	23-25	Gobo 7	step
26-28	Gobo 8	step	

DMX protocol

Channel	DMX Value	Function	Type of control
	29-31	Gobo 9	step
		<i>Rotation - set rotation on channel 20</i>	
	32-34	Gobo 1	step
	35-37	Gobo 2	step
	38-40	Gobo 3	step
	41-43	Gobo 4	step
	44-46	Gobo 5	step
	47-49	Gobo 6	step
	50-52	Gobo 7	step
	53-55	Gobo 8	step
	56-59	Gobo 9	step
		<b><u>Shaking gobos from slow to fast</u></b>	
		<i>Index - set indexing on channel 20</i>	
	60-67	Gobo 1	proportional
	68-75	Gobo 2	proportional
	76-83	Gobo 3	proportional
	84-91	Gobo 4	proportional
	92-99	Gobo 5	proportional
	100-107	Gobo 6	proportional
	108-115	Gobo 7	proportional
	116-123	Gobo 8	proportional
	124-129	Gobo 9	proportional
		<b><u>Shaking gobos from slow to fast</u></b>	
		<i>Rotation - set rotation on channel 20</i>	
	130-137	Gobo 1	proportional
	138-145	Gobo 2	proportional
	146-153	Gobo 3	proportional
	154-161	Gobo 4	proportional
	162-169	Gobo 5	proportional
	170-177	Gobo 6	proportional
	178-185	Gobo 7	proportional
	186-193	Gobo 8	proportional
	194-199	Gobo 9	proportional
	200 - 201	Open/hole	step
	202 - 222	Forwards gobo wheel rotation from fast to slow	proportional
	223 - 243	Backwards gobo wheel rotation from slow to fast	proportional
	244 - 249	Random gobo selection by audio control (Set microphone sensitivity in menu „Personality“)	step
	250 - 255	Auto random gobo selection from fast to slow	proportional
<b>20</b>		<b>Rot. Gobo indexing/rotation</b>	
		<b><i>Gobo indexing - set position on channel 19</i></b>	
	0 - 255	Gobo indexing (128=default)	proportional
		<b><i>Gobo rotation - set position on channel 19</i></b>	
	0	No rotation	step
	1 - 127	Forwards gobo rotation from fast to slow	proportional
	128	No rotation (128=default)	step
	129 - 255	Backwards gobo rotation from slow to fast	proportional
<b>21</b>		<b>Rot. Gobo indexing/rotation - fine</b>	

## DMX protocol

Channel	DMX Value	Function	Type of control
	0-255	Fine indexing/rotation (0=default)	proportional
<b>22</b>		<b>Prism</b>	
		<i>Note: prism and frost cannot be inserted into light beam at the same time</i>	
	0 - 19	Open position/hole (0=default)	step
	20 - 127	8-facet rotating prism	step
		Prism/gobo macros	
		<i>The following channels are blocked: Rotating gobo wheel, Rot. Gobo indexing and rotation, Rot. Gobo wheel fine rotation</i>	
	128 - 135	Macro 1	step
	136 - 143	Macro 2	step
	144 - 151	Macro 3	step
	152 - 159	Macro 4	step
	160 - 167	Macro 5	step
	168 - 175	Macro 6	step
	176 - 183	Macro 7	step
	184 - 191	Macro 8	step
	192 - 199	Macro 9	step
	200 - 207	Macro 10	step
	208 - 215	Macro 11	step
	216 - 223	Macro 12	step
	224 - 231	Macro 13	step
	232 - 239	Macro 14	step
	240 - 247	Macro 15	step
	248 - 255	Macro 16	step
<b>23</b>		<b>Prism rotation</b>	
	0	No rotation	step
	1 - 127	Forwards rotation from fast to slow	proportional
	128	No rotation (128= default)	step
	129-255	Backwards rotation from slow to fast	proportional
<b>24</b>		<b>Frost</b>	
		<i>Note: prism and frost cannot be inserted into light beam at the same time</i>	
	0	Open (0=default)	step
	1 - 179	Frost from 0% to 100%	proportional
	180 - 189	100% frost	step
	190 - 211	Pulse closing from slow to fast	proportional
	212 - 233	Pulse opening from fast to slow	proportional
	234 - 255	Ramping from fast to slow	proportional
<b>25</b>		<b>Focus</b>	
	0 - 255	Continuous adjustment from far to near (128=default)	proportional
<b>26</b>		<b>Focus - fine</b>	
	0- 255	Fine focusing (0=default)	proportional
<b>27</b>		<b>Shutter/ strobe</b>	
	0 - 31	Shutter closed	step
	32 - 63	Shutter open (32=default)	step
	64 - 95	Strobe-effect from slow to fast	proportional
	96 - 127	Shutter open	step
	128 - 143	Opening pulse in sequences from slow to fast	proportional

DMX protocol

Channel	DMX Value	Function	Type of control
	144 - 159	Closing pulse in sequences from fast to slow	proportional
	160 - 191	Shutter open	proportional
	192 - 223	Random strobe-effect from slow to fast	proportional
	224 - 255	Shutter open	step
<b>28</b>		<b>Dimmer intensity</b>	
	0 - 255	Dimmer intensity from 0% to 100% (0=default)	proportional
<b>29</b>		<b>Dimmer intensity - fine</b>	
	0 - 255	Fine dimming (0=default)	proportional
Copyright © 2021 Robe Lighting s.r.o. - All rights reserved			
All Specifications subject to change without notice			

<b>Robin Cuete - colours on Virtual Colour Wheel</b>				
<b>Colour name</b>	<b>Cyan (DMX)</b>	<b>Magenta (DMX)</b>	<b>Yellow (DMX)</b>	<b>Colour Wheel (DMX)</b>
Filter 4 (Medium Bastard Amber)	0	140	175	0
Filter 10 (Medium Yellow)	0	120	223	0
Filter 19 (Fire)	0	236	0	177
Filter 24 (Scarlet)	137	255	0	134
Filter 58 (Lavender)	25	182	91	0
Filter 68 (Sky Blue)	184	152	0	0
Filter 71 (Tokyo Blue)	0	0	0	137
Filter 79 (Just Blue)	186	161	0	0
Filter 88 (Lime Green)	78	0	217	0
Filter 90 (Dark Yellow Green)	196	0	227	0
Filter 100 (Spring Yellow)	0	83	221	0
Filter 101 (Yellow)	0	122	221	0
Filter 102 (Light Amber)	0	115	189	0
Filter 103 (Straw)	0	104	185	0
Filter 104 (Deep Amber)	0	144	239	0
Filter 105 (Orange)	0	180	250	0
Filter 781 (Terry Red)	0	255	242	169
Filter 111 (Dark Pink)	0	177	179	0
Filter 115 (Peacock Blue)	238	0	194	0
Filter 505 (Sally Green)	251	0	198	0
Filter 117 (Steel Blue)	148	0	168	0
Filter 118 (Light Blue)	207	0	174	0
Filter 724 (Ocean Blue)	255	47	0	0
Filter 725 (Old Steel Blue)	255	98	0	0
Filter 121 (Filter Green)	158	0	255	0
Filter 128 (Bright Pink)	0	222	177	0
Filter 131 (Marine Blue)	198	0	143	0
Filter 132 (Medium Blue)	255	0	83	0
Filter 134 (Golden Amber)	0	175	255	0
Filter 135 (Deep Golden Amber)	0	214	255	0
Filter 136 (Pale Lavender)	0	170	97	0
Filter 137 (Special Lavender)	0	121	99	0
Filter 138 (Pale Green)	70	35	197	0
Filter 139 (Primary Green)	255	0	250	0
Filter 141 (Bright Blue)	231	0	130	0
Filter 147 (Apricot)	0	156	217	0
Filter 148 (Bright Rose)	0	224	209	0
Filter 152 (Pale Gold)	0	157	197	0
Filter 154 (Pale Rose)	0	146	173	0
Filter 157 (Pink)	0	204	211	0
Filter 158 (Deep Orange)	0	205	255	0
Filter 162 (Bastard Amber)	0	134	193	0
Filter 164 (Flame Red)	0	255	255	0
Filter 165 (Daylight Blue)	200	0	67	0
Filter 169 (Lilac Tint)	0	167	145	0
Filter 170 (Deep Lavender)	0	165	67	0

<b>Colour name</b>	<b>Cyan (DMX)</b>	<b>Magenta (DMX)</b>	<b>Yellow (DMX)</b>	<b>Colour Wheel (DMX)</b>
Filter 172 (Lagoon Blue)	214	0	149	0
Filter 179 (Chrome Orange)	0	159	236	0
Filter 180 (Dark Lavender)	141	155	0	0
Filter 181 (Congo Blue)	175	210	0	0
Filter 197 (Alice Blue)	234	138	0	0
Filter 201 (Full C.T. Blue)	169	0	128	0
Filter 202 (Half C.T. Blue)	141	0	92	0
Filter 203 (Quarter C.T. Blue)	114	0	130	0
Filter 204 (Full C.T. Orange)	0	172	255	0
Filter 205 (Half C.T. Orange)	0	140	199	0
Filter 206 (Quarter C.T. Orange)	0	137	152	0
Filter 247 (Filter Minus Green)	0	160	121	0
Filter 248 (Half Minus Green)	0	90	86	0
Filter 281 (Three Quarter C.T. Blue)	150	0	118	0
Filter 285 (Three Quarter C.T. Orange)	0	150	239	0
Filter 352 (Glacier Blue)	198	0	122	0
Filter 353 (Lighter Blue)	208	0	151	0
Filter 715 (Cabana Blue)	255	101	0	0
Filter 778 (Millennium Gold)	0	202	255	0
Filter 328 (Follies Pink)	0	225	148	0